

TECHNICAL MANUAL



PPM[®] High-Strength Anchor Bolt

Heavy-duty bolted connections

Version PEIKKO GROUP 02/2021



PPM® High-Strength Anchor Bolt

Heavy-duty bolted connections

- Standardized, tested and widely approved high-strength steel anchor bolt system
 - Pre-defined design parameters
 - Quick deliveries directly from stock
 - Certified production
- Wide range of products for demanding anchoring purposes
- Accessories for quick and easy installation
- Easy to design with free Peikko Designer® software



High strength steel PPM® Anchor Bolts are used to anchor concrete or steel structures or machinery into concrete base structures in demanding anchoring applications. The anchors are embedded into concrete and the structures are fastened to bolts by nuts and washers. The joint between two structures is then grouted.

The system consists of a wide range of headed and straight anchor bolts, installation accessories, and tools for designers. Headed bolts are used typically in shallow structures for end anchoring, whereas straight bolts are used for lap splices. In addition to plain finish bolts, the products are also available as ECO or Hot-Dip galvanized. Installation templates are provided to ensure easy and correct installation of the anchor bolts.

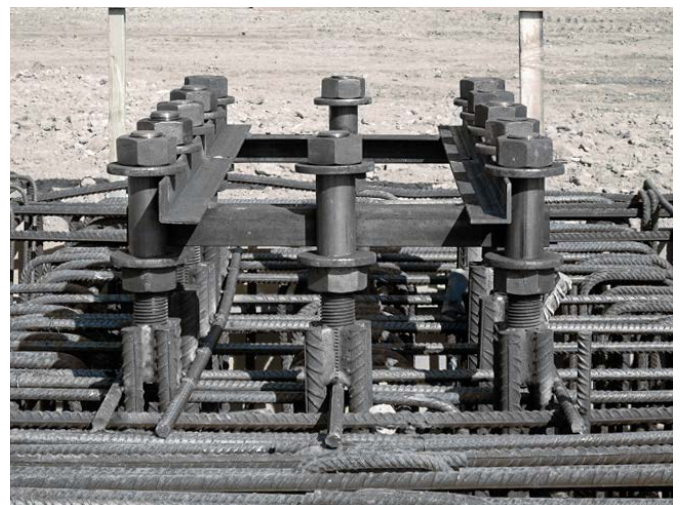

www.peikko.com

CONTENTS

About PPM® High-Strength Anchor Bolt.....	5
1. Product properties.....	5
1.1 Structural behavior.....	7
1.1.1 Temporary conditions	7
1.1.2 Final conditions.....	7
1.2 Application conditions.....	8
1.2.1 Loading and environmental conditions.....	8
1.2.2 Interaction with base structure	9
1.2.3 Positioning of the anchor bolt.....	9
1.3 Other properties.....	10
2. Resistances	12
2.1 Tensile, compressive, and shear resistances.....	12
2.2 Combined axial and shear load	16
2.3 Fire resistance.....	16
Selecting PPM® High-Strength Anchor Bolt.....	17
Annex A – Supplementary reinforcement to resist tension load	19
A1: Concrete cone reinforcement	19
A2: Splitting reinforcement.....	20
Annex B – Supplementary reinforcement to resist shear load.....	21
B1: Edge reinforcement	21

Annex C – Supplementary reinforcement to resist compression load ..	22
C1: Concrete cone reinforcement for punching.....	22
C2: Partially loaded areas, Splitting reinforcement	23
Annex D – Transverse reinforcement in the lap zone	25
Annex E – Alternative use of PPM® P High-Strength Anchor Bolts	26
Annex F – Alternative means to transfer shear load	27
Installation of PPM® High-Strength Anchor Bolts.....	28



About PPM® High-Strength Anchor Bolt

1. Product properties

PPM® Anchor Bolts are cast-in-place anchors used to connect structural and non-structural elements to concrete in all types of buildings, warehouses, halls, bridges, dams, and power plants.

PPM® Anchor Bolts are available in several standard models that are suitable for different application solutions, loading conditions, and cross-sections. Anchor bolts are cast into concrete and transfer loads from the attachment to the base structure.

The product range consists of

- Headed anchor bolts, type PPM® L
- Straight anchor bolts, type PPM® P
- Installation templates.

PPM® L Anchor Bolt



PPM® P Anchor Bolt



Type L bolt anchorage is achieved with a headed studs. Loads are transferred through the bearing of the head against hardened concrete. Due to their relatively short anchorage length, PPM® L Anchor Bolts are particularly suitable for use in shallow structures (e.g. foundations, slabs, beams).

Type P bolt anchorage is achieved by splicing, whereby the bolt overlaps the main reinforcement. Loads are transferred through the bond of the ribbed bars. The primary use of PPM® P Anchor Bolts is in structures with sufficient depth (e.g. base columns, columns). Alternative usages are shown in Annex E.

PPM® Anchor Bolts are pre-designed to be compatible with PEC® Column Shoes, SUMO® Wall Shoes, and Beam Shoes, providing a solution for most precast connections (e.g. column to foundation, column to base column, column to column, wall to foundation, wall to wall, beam to column, beam to wall), as well as to secure steel columns or even machine fixings.

Anchor bolts are cast into the base structure together with the main and supplementary reinforcement, as detailed in Annexes A, B, C, and D of this manual. The connection is achieved by fastening the anchor bolt to the base plate using nuts and washers. To finalize the connection, the joint is grouted with non-shrinking grouting material.

Peikko Bolted Connections can be designed to resist axial forces, bending moments, shear forces, combinations of the above, and fire exposure. The appropriate type and quantity of PPM® Anchor Bolts to be used in a connection may be selected and the resistance of the connection verified by using the Peikko Designer® software (download from www.peikko.com).

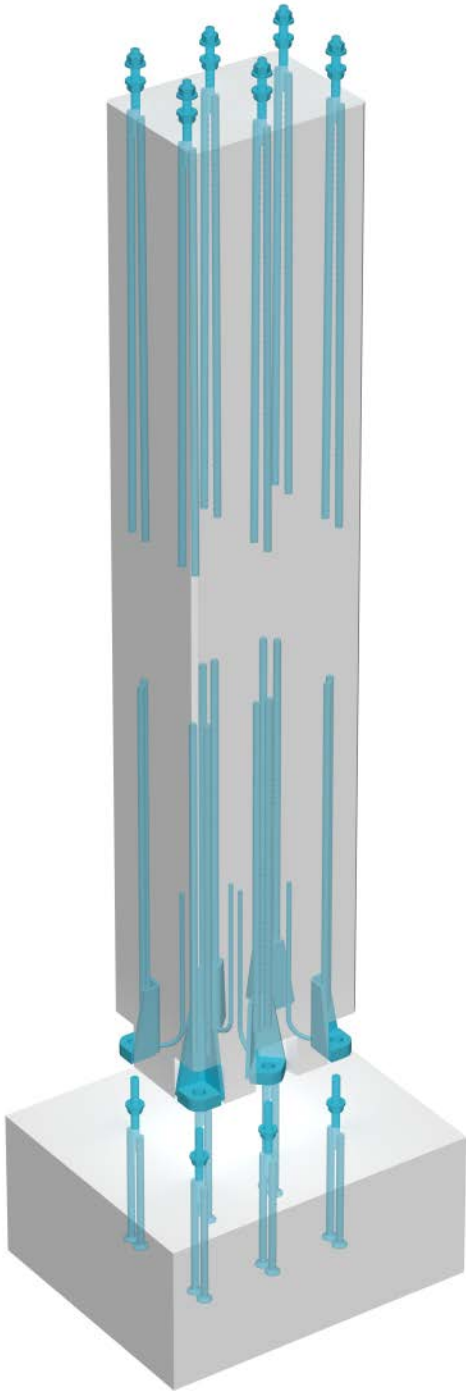

Figure 1. *PPM® L Anchor Bolts in a concrete column to footing connection.*

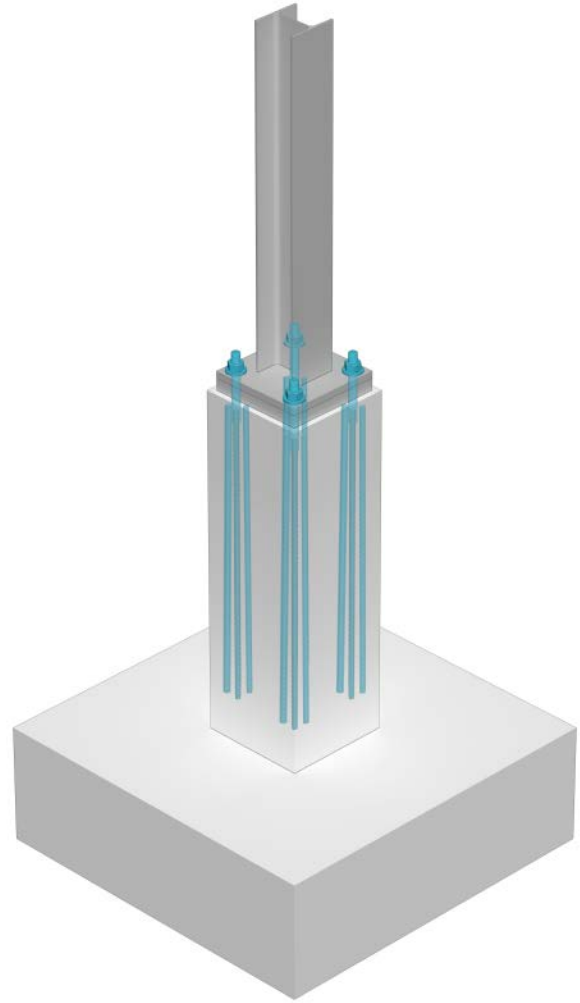

Figure 2. *PPM® P Anchor Bolts in a steel column to base column connection.*

1.1 Structural behavior

The loads on fixtures are transmitted to the anchor bolts as statically equivalent, tension, compression, and shear forces. Moment can be resisted by development of a force couple between tensile and compressive forces. The selected size and number of anchor bolts should be sufficient for the loads.

1.1.1 Temporary conditions

In the erection stage, the forces acting on anchor bolts are caused principally by self-weight of the attachment as well as by the bending moment and shear force due to wind load. Since the joint is not grouted, all of the forces are carried solely by anchor bolts. In addition, bolts must be verified for buckling and bending. The open joint between the attachment and the base structure must be grouted with a non-shrink grouting material and the grout must harden before loads from other structures can be applied.

1.1.2 Final conditions

In the final stage, after the grout has reached the designed strength, the connection acts as a reinforced-concrete structure. The grout serves as the connection between the attachment and the base structure, transferring compression and shear loads. The grout must have a design compressive strength at least equal to the strength of the highest grade of concrete used in the connected elements.

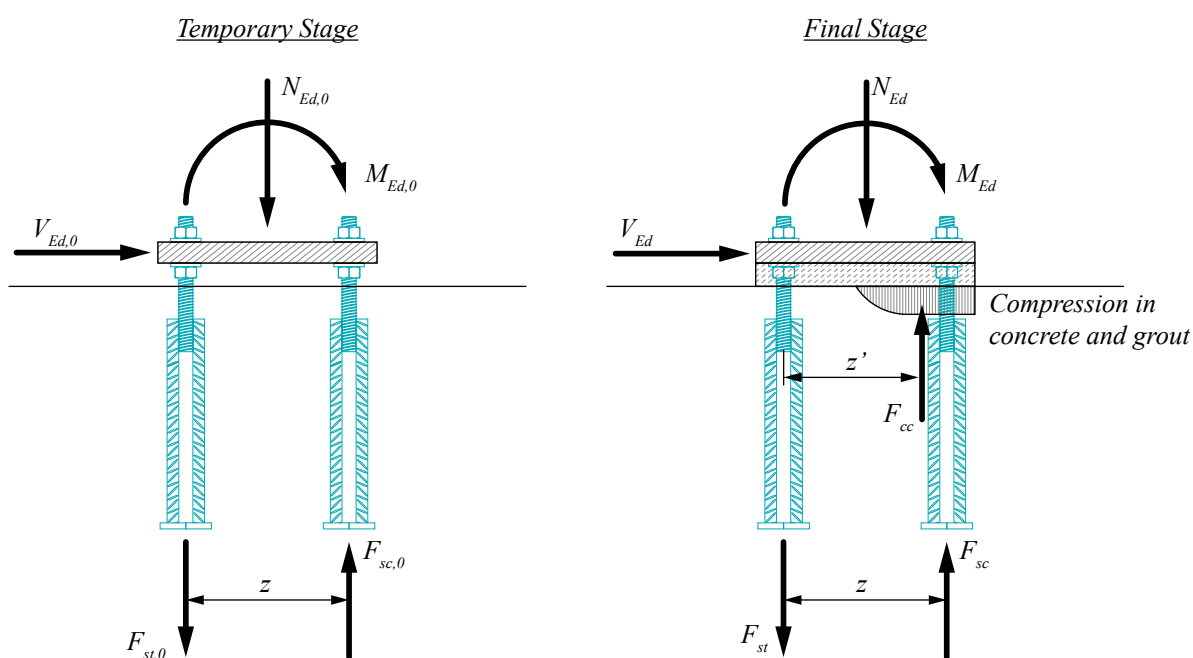

Figure 3. Structural behavior of the bolted connection under temporary and final conditions.

1.2 Application conditions

The standard models of PPM® Anchor Bolts are pre-designed for use under the conditions mentioned in this section. If these conditions are not met, please contact Peikko Technical Support for custom-designed PPM® Anchor Bolts.

1.2.1 Loading and environmental conditions

PPM® Anchor Bolts are designed to carry static loads. To ensure resistance to corrosion the concrete cover of PPM® Anchor Bolts including washers and nuts must observe the minimum values determined according to the environmental exposure class and intended operating life. As an alternative to concrete cover, Peikko offers two standard surface coating options: ECO Galvanizing and Hot-Dip Galvanizing. Other anti-corrosion methods such as painting on site can also be utilized. For further information please contact Peikko Technical Support.

ECO Galvanizing is an economical and ecological way to protect bolts against corrosion, which allows anchor bolts to be galvanized partly or completely. The galvanizing method is a thermally sprayed zinc coating (according to EN ISO 2063). The minimum coating thickness is 100 µm, which fulfills environmental class C3 of standard EN 9223:2012.

Hot-Dip Galvanized bolts (according to EN ISO 1461) are dipped completely in a bath of molten zinc. The minimum coating thickness is 55 µm, which fulfills environmental class C3 of standard EN 9223:2012.

Examples for ordering galvanized bolts:

- a) ECO Galvanized ⇒ Name: **PPM30P-ECO**
- b) Hot-Dip Galvanized ⇒ Name: **PPM36L-HDG**

*a) ECO Galvanized
PPM® Bolt*

*b) Hot-Dip Galvanized
PPM® Bolt*



Figure 4. Surface coating options.

Table 1. Protection of anchor bolts against corrosion in different environmental conditions. Structural Class: S4, Allowance for deviation: $\Delta c_{dev} = 10$ mm.

Exposure class	Required nominal concrete cover of anchor bolts according to EN 1992-1-1 c_{nom} [mm]
X0	20
XC1	25
XC2 /XC3	35
XC4	40
XD1 /XS1	45
XD2 /XS2	50
XD3 / XS3	55

1.2.2 Interaction with base structure

PPM® Anchor Bolts are pre-designed for use in reinforced base structures (e.g. foundations, slabs, base columns, columns, walls). The standard properties of PPM® Anchor Bolts are valid for reinforced normal weight concrete with a strength class in the range C20/25 to C50/60. The anchor bolt may be anchored in cracked or non-cracked concrete. In general, it is conservative to assume that the concrete will be cracked over its service life.

1.2.3 Positioning of the anchor bolt

PPM® Anchor Bolts are embedded in concrete up to the marking of the anchorage depth. Where possible, anchor bolts should be arranged symmetrically. The layout must also be coordinated with existing reinforcement to ensure that the bolts can be installed in the intended location.

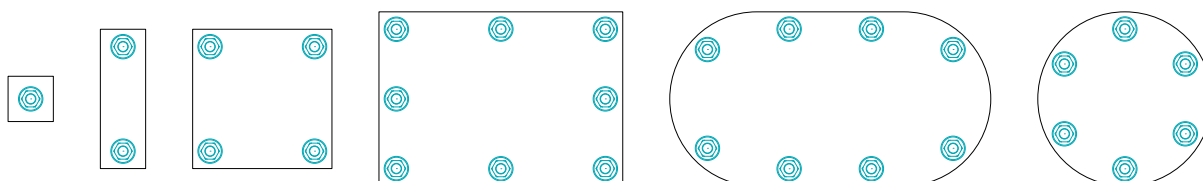

Figure 5. Examples with layout patterns of PPM® Anchor Bolts.

When placing PPM® L Anchor Bolts, the spacing (s_{min}), edge distance (c_{min}), and base structure thickness (h_{min}) must not fall below the minimum values shown in Table 2. It should be noted that the minimum thicknesses (h_{min}) in Table 2 are for base structures cast directly against soil, $h_{min} = h_{ef} + k + c_{nom}$, hence $c_{nom} = 85$ mm.

Table 2. Positioning of PPM® L Anchor Bolts in base structure.

Anchor Bolt	c_{min} [mm]	s_{min} [mm]	h_{min} [mm]	h_{ef} [mm]	k [mm]
PPM 30 L	120	130	600	502	13
PPM 36 L	140	160	655	558	12
PPM 39 L	150	180	755	677	13
PPM 45 L	160	200	865	767	13
PPM 52 L	180	280	990	890	15
PPM 60 L	180	280	1155	1055	15

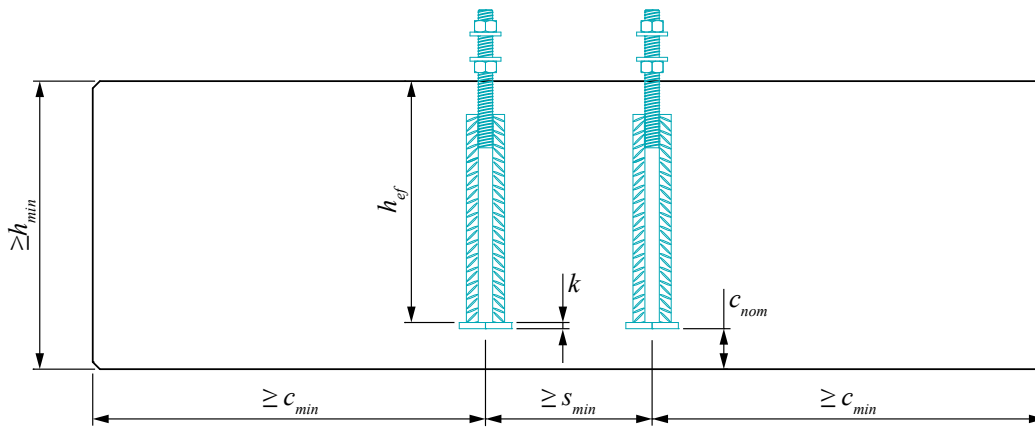

Figure 6. Installed PPM® L Anchor Bolt.

When placing PPM® P Anchor Bolts, the minimum edge distance should comply with the concrete cover thickness according to EN 1992-1-1, section 4.

The spacing of the bolts in the group shall be such that the concrete can be placed and compacted satisfactorily for the development of adequate bond, in EN 1992-1-1, section 8.2. The arrangement of lapped bars should comply with EN 1992-1-1, section 8.7.

1.3 Other properties

PPM® Anchor Bolts are fabricated of ribbed reinforcement steel bars with the following material properties:

Ribbed bars	B500B	EN 10080
Threaded bars	High strength steel	$f_{yk} \geq 640$ MPa
	Property class 8.8	$f_{uk} \geq 800$ MPa
		Mechanical properties according to EN ISO 898-1

Standard delivery for each anchor bolt includes two hexagonal nuts and two washers:

Washers	S355J2 + N	EN 10025-2
Nuts	Property class 10	EN ISO 4032 / EN ISO 898-2

Peikko Group’s production units are externally controlled and periodically audited on the basis of production certifications and product approvals by various organizations.

Manufacturing method	
Ribbed bars	Mechanical cutting
Threads	Rolling
Welds	MAG welding
Anchor head	Forging

Manufacturing tolerances	
Length	± 10 mm
Thread length	+ 5, -0 mm

Table 3. Dimensions [mm], weight [kg], and colour codes of PPM® L Anchor Bolts.

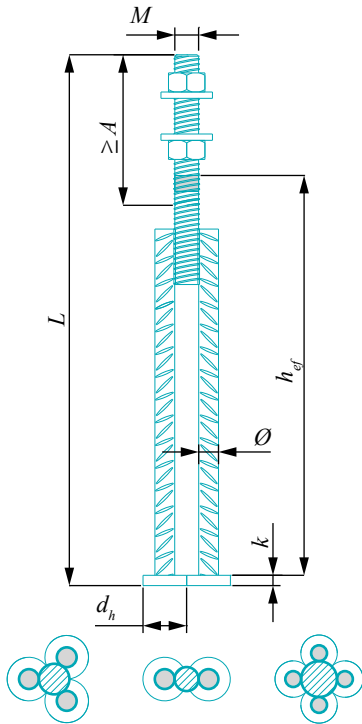

	PPM 30 L	PPM 36 L	PPM 39 L	PPM 45 L	PPM 52 L	PPM 60 L
M Metric thread	M30	M36	M39	M45	M52	M60
A Minimum thread length	190	190	190	220	250	310
Stress area of the thread	561	817	976	1306	1758	2362
Ø	2Ø25	4Ø20	3Ø25	4Ø25	4Ø32	4Ø32
L	670	740	880	980	1140	1330
Washer	Ø65-8	Ø80-8	Ø90-10	Ø100-10	Ø100-12	Ø115-15
h_{ef}	502	558	677	767	890	1055
d_h	55	46	55	55	70	70
k	13	12	13	13	15	15
Weight	6.2	9.4	12.7	18.6	32.6	42.0
Color code	Black	Red	Brown	Purple	White	

Table 4. Dimensions [mm], weight [kg], and colour codes of PPM® P Anchor Bolts.

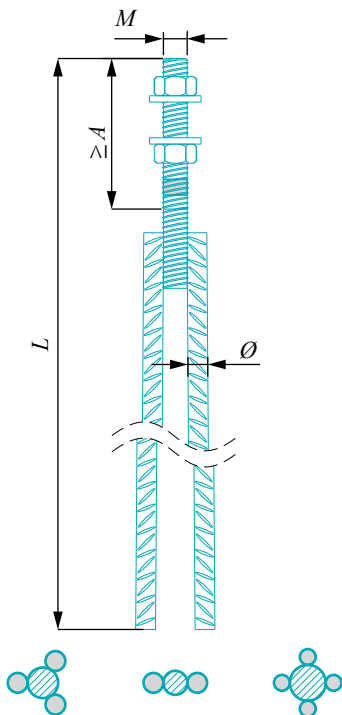

	PPM 30 P	PPM 36 P	PPM 39 P	PPM 45 P	PPM 52 P	PPM 60 P
M Metric thread	M30	M36	M39	M45	M52	M60
A Minimum thread length	190	190	190	220	250	310
Stress area of the thread	561	817	976	1306	1758	2362
Ø	2Ø25	4Ø20	3Ø25	4Ø25	4Ø32	4Ø32
L	1705	1450	1815	1825	1930	2490
Washer	Ø65-8	Ø80-8	Ø90-10	Ø100-10	Ø100-12	Ø115-15
Weight	14.1	16.0	23.5	31.4	52.1	71.0
Color code	Black	Red	Brown	Purple	White	

2. Resistances

2.1 Tensile, compressive, and shear resistances

The resistances of PPM® Anchor Bolts are determined by a design concept that makes reference to the following standards:

- Specification CEN/TS 1992-4-1:2009
- Specification CEN/TS 1992-4-2:2009
- EN 1992-1-1:2004/AC:2010
- EN 1993-1-1:2005/AC:2009
- EN 1993-1-8:2005/AC:2005
- ETAG 001:2010, Annex C.

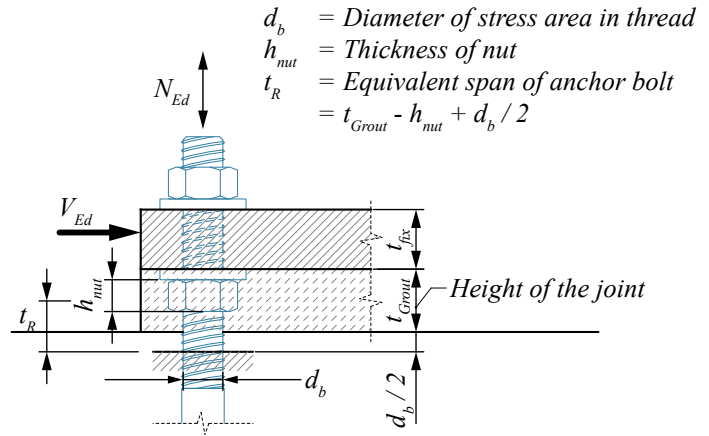

Figure 7. Loads and parameters characterizing the joint.

The resistance of PPM® Anchor Bolt connections is defined by bolt steel or anchorage to concrete strength. The required verifications are summarized later in this section. If the anchor bolt's tensile or shear resistance of steel cannot be fully developed due to concrete failure then the supplementary reinforcement may be used to carry the forces from the anchor bolt. It is recommended that the resistance be calculated and the required reinforcement for the bolted connections be assigned using the Peikko Designer® software.

Table 5. Design values for tensile or compressive resistance of individual PPM® Anchor Bolt. (Steel strength). The resistances are determined in accordance with ETAG 001.

		PPM 30	PPM 36	PPM 39	PPM 45	PPM 52	PPM 60
N_{Rd}	[kN]	299	436	521	697	938	1260
$N_{Rd,0}$							

Table 6. Design values for shear resistance of individual PPM® Anchor Bolt. (Steel strength). The resistances are determined in accordance with EN 1993-1-8, section 6.2.2 (7).

Anchor Bolt	V_{Rd} [kN] Final Stage	$V_{Rd,0}$ [kN] Erection Stage	t_{GROUT} [mm]
PPM 30	89	53	50
PPM 36	130	88	55
PPM 39	155	104	60
PPM 45	207	144	65
PPM 52	219	215	70
PPM 60	225	225	80

NOTE 1: Resistances V_{Rd} and $V_{Rd,0}$ in Table 6 are valid for height of joint equal to t_{GROUT} .

NOTE 2: The base plate design must meet the requirements for the anchor bolt capacity.

NOTE 3: Resistances shown in Tables 5 and 6 are without simultaneous action of axial and shear load. For combined resistance, see section 2.2 of this manual.

Table 7. Required verification for PPM® Anchor Bolts loaded in tension.

The use of Peikko Designer® software is recommended to prove the resistance of the following verifications

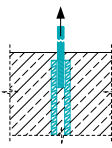
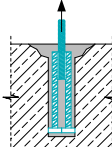
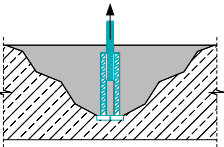
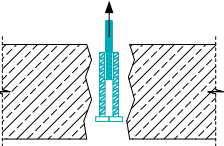
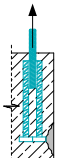
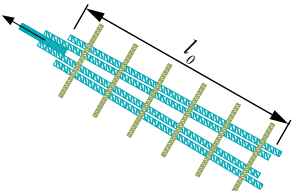
Failure mode	Example	PPM® L Anchor Bolts	PPM® P Anchor Bolts
Steel strength		Required (for most loaded bolt)	Required (for most loaded bolt)
Pull-out strength		Required (for most loaded bolt)	Required (for most loaded bolt)
Concrete cone strength ¹⁾		Required (for most loaded bolt)	Not applicable
Splitting strength ²⁾		Required (for anchor group)	Not applicable
Blow-out strength ³⁾		Required (for anchor group)	Not applicable
Splicing length ⁴⁾ • Bond strength		Not applicable	Required (for most loaded bolt)

¹⁾ Not required if supplementary reinforcement is provided according to Annex A1.

²⁾ Not required if the edge distance in all directions $c \geq 1.5 h_{ef}$ for one bolt and $c \geq 1.8 h_{ef}$ for fastenings with more than one anchor bolt or if supplementary reinforcement is provided according to Annex A2.

³⁾ Not required if the edge distance in all directions $c \geq 0.5 h_{ef}$.

⁴⁾ See Annex D for required transverse reinforcement in the lap zone.

Table 8. Required verification for PPM® Anchor Bolts loaded in compression.

The use of Peikko Designer® software is recommended to prove the resistance of the following verifications

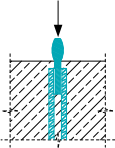
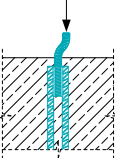
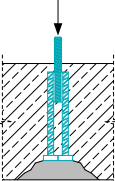
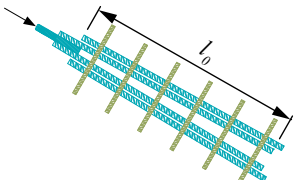
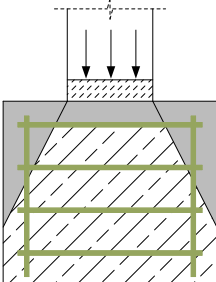
Failure mode	Example	PPM® L Anchor Bolts	PPM® P Anchor Bolts
Steel strength		Required (for most loaded bolt)	Required (for most loaded bolt)
Buckling strength ¹⁾		Required (for most loaded bolt)	Required (for most loaded bolt)
Punching strength under the anchor head ²⁾		Required (for anchor group)	Not applicable
Splicing length ³⁾ • Bond strength		Not applicable	Required (for most loaded bolt)
Partially loaded areas ⁴⁾ • Local crushing • Transverse tension forces		Required only in the final stage (for the base structure)	Required only in the final stage (for the base structure)

¹⁾ Not required if the height of the joint does not exceed the grouting thicknesses stated in the installation instructions of this manual. See Table 6 for t_{Grout}

²⁾ Not required if the thickness of the base structure ensures a sufficient concrete layer under the anchor head or if supplementary reinforcement is provided. Details can be found from Annex C1.

³⁾ See Annex D for the required transverse reinforcement in the lap zone.

⁴⁾ See Annex C2 for design guidelines and the required splitting reinforcement.

Table 9. Verificación que se requiere para los tornillos de anclaje PPM® con carga de cortante.

The use of Peikko Designer® software is recommended to prove the resistance of the following verifications

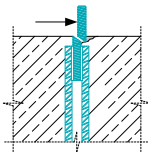
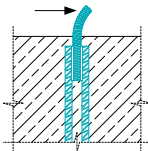
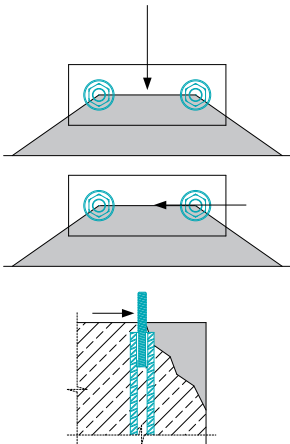
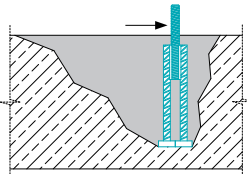
Failure mode	Example	PPM® L Anchor Bolts	PPM® P Anchor Bolts
Steel strength		Required (for most loaded bolt)	Required (for most loaded bolt)
Steel strength with lever arm ¹⁾		Required (for most loaded bolt)	Required (for most loaded bolt)
Concrete edge strength ²⁾ <ul style="list-style-type: none"> • Shear perpendicular to the edge • Shear parallel to the edge • Inclined shear 		Required (for anchor group)	Required (for anchor group)
Concrete pry-out strength		Required (for anchor group)	Not applicable

¹⁾ Not required in the final stage if the height of the joint does not exceed the grouting thicknesses stated in the installation instructions of this manual. See Table 6 for t_{Grout} . It should be noted that the check always applies in the erection stage

²⁾ Not required if the edge distances in all directions $c \geq \min(10 h_{ef}; 60\varnothing)$ or if supplementary reinforcement is provided according to Annex B1.

2.2 Combined axial and shear load

When axial and shear forces strain the bolt simultaneously the interaction should be checked by satisfying the following equations for different failure modes and design stages.

WITH RESPECT TO STEEL VERIFICATIONS

Bolts in Erection Stage

The simultaneous **axial** force and **shear** force in each bolt shall satisfy the condition:

$$\frac{|N_{Ed,0}^I|}{N_{Rd,0}} + \frac{|V_{Ed,0}^I|}{V_{Rd,0}} \leq 1 \quad \text{Based on ETA-13/0603, Eq. (1)}$$

Bolts in Final Stage

The simultaneous tensile force and shear force in each bolt shall satisfy the condition:

$$\frac{|N_{Ed}^I|}{1.4N_{Rd}} + \frac{|V_{Ed}^I|}{V_{Rd}} \leq 1 \quad \text{EN 1993-1-8, Table 3.4}$$

$$\frac{|N_{Ed}^I|}{N_{Rd}} \leq 1 \quad \text{EN 1993-1-8, Table 3.4}$$

Where

$V_{Rd,0}$	=	shear resistance of bolt, Erection Stage
V_{Rd}	=	shear resistance of bolt, Final Stage
$N_{Rd,0}$	=	axial resistance of bolt, Erection Stage
N_{Rd}	=	axial resistance of bolt, Final Stage
$V_{Ed,0}^I$	=	shear load on a single bolt, Erection Stage
V_{Ed}^I	=	shear load on a single bolt, Final Stage
$N_{Ed,0}^I$	=	axial load on a single bolt, Erection Stage
N_{Ed}^I	=	axial load on a single bolt, Final Stage

WITH RESPECT TO CONCRETE VERIFICATIONS (applies only for PPM® L Anchor Bolts)

Bolts without supplementary reinforcement

The simultaneous **tensile** force and **shear** force shall satisfy either one or both of following conditions:

$$|\beta_N| + |\beta_V| \leq 1.2 \quad \text{CEN/TS 1992-4-2, Eq. (47)}$$

$$|\beta_N|^{1.5} + |\beta_V|^{1.5} \leq 1 \quad \text{CEN/TS 1992-4-2, Eq. (48)}$$

Bolts with supplementary reinforcement

The simultaneous **tensile** force and **shear** force shall satisfy the condition:

$$|\beta_N|^{2/3} + |\beta_V|^{2/3} \leq 1 \quad \text{CEN/TS 1992-4-2, Eq. (49)}$$

It should be noted that if the supplementary reinforcement is designed to carry tension **and** shear forces, Eq.(47) and/or Eq. (48) applies.

where

β_N = largest degree of utilization from concrete verifications under tensile force

β_V = largest degree of utilization from concrete verifications under shear force

NOTE: Failure modes β_N and β_V are those not covered by supplementary reinforcement

2.3 Fire resistance

The fire resistance of bolted connection should be verified in accordance with EN 1992-1-2. If the fire resistance of the connection is insufficient, the concrete cover must be increased or alternative means used to reach the intended fire resistance class. Please contact Peikko Technical Support for custom designs.

Selecting PPM® High-Strength Anchor Bolt

The following aspects must be considered when selecting an appropriate type of PPM® Anchor Bolt to be used in bolted connections:

- Resistances
- Properties of the grouting
- Properties of the base structure
- Position and arrangement of the anchor bolts in the base structure
- Design value of actions.

The resistance of Peikko Bolted Connections should be verified for the following design situations:

- Erection stage
- Final stage
- Fire situation
- Environmental exposure conditions.

Peikko Designer® Column Connection software

Peikko Designer® is software to be used for designing column connections with Peikko's products. It can be downloaded free of charge from www.peikko.com. The Column Connection module enables the user to design connections to resist actual loadings and optimize the connections to meet the requirements of the entire project. The software's output reports can also be used to verify the design and output drawings as details of the connection. The summary of the products in the project helps to plan material flow during construction.

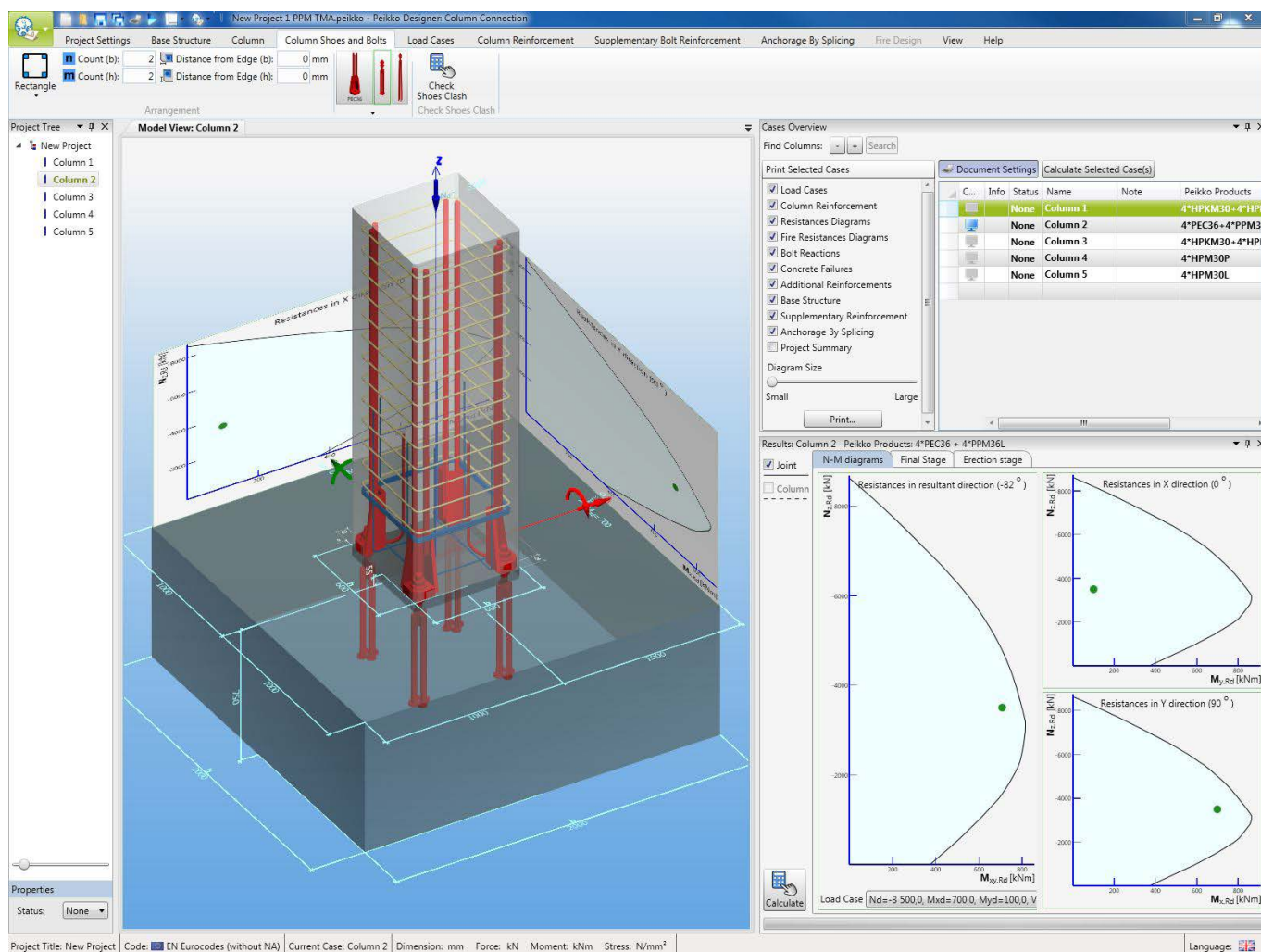

Figure 8. User interface of Peikko Designer® Column Connection.

SELECTING

Typically, the following steps are used for the selection procedure:

USER INPUT

- Materials for column, structure under column, and grouting
- Geometries of the column and structure under column
- Design values of the actions – erection, final, and fire stages
- **NOTE:** Second order effects should be included in the load case
- Type of column shoes and anchor bolts
- Column shoe arrangement
- Column reinforcement (optional).

PEIKKO DESIGNER OUTPUT

- N-M interaction diagram (axial force-bending moment diagram) of joint in final and fire stage
- N-M interaction diagram of reinforced column
- Calculation results for column connection in final stage
- Calculation results for column connection in erection stage
- Supplementary reinforcement details
- Summary of products in the project.

Annex A – Supplementary reinforcement to resist tension load

A1: Concrete cone reinforcement

If the concrete cone resistance is exceeded, supplementary reinforcement for the tension load should be provided. Detailing of hanger reinforcement for PPM® L Anchor Bolts is shown in the following figure. The required quantities of stirrups and surface bars are given in *Table 10*. Alternative reinforcement arrangements can be calculated using the Peikko Designer® Column Connection software in accordance with CEN/TS 1992-4-2.

Table 10. Concrete cone reinforcement (B500B).

Anchor Bolt	Stirrups (per bolt) ①	Surface bars ②	c_{nom} [mm]	$R_{1,max}$ [mm]	$R_{2,max}$ [mm]	h_{ef} [mm]	Width of stirrup b [mm]
PPM 30 L	4 $\emptyset 12$	$\emptyset 8$	35	170	-	502	170
PPM 36 L	4 $\emptyset 14$	$\emptyset 10$	35	195	-	558	180
PPM 39 L	4 $\emptyset 14$	$\emptyset 10$	35	220	-	677	190
PPM 45 L	4 $\emptyset 16$	$\emptyset 10$	35	250	-	767	210
PPM 52 L	4 + 2 $\emptyset 16$	$\emptyset 14$	35	280	315	890	250
PPM 60 L	4 + 4 $\emptyset 16$	$\emptyset 14$	35	300	335	1055	250

The reinforcement from *Table 10* can be directly applied under the following conditions:

- The concrete strength class of the base structure is equal to or greater than C25/30 (good bond conditions)
- The nominal concrete cover is equal to or smaller than 35 [mm]
- The minimum clear distance (a) between adjacent legs of stirrups should not be less than 21 [mm], requirement according to EN 1992-1-1, section 8.2 (maximum size of aggregate = 16 mm)
- The stirrups are located inside the stress cone, with a radial distance to the leg no further than $R_{1,max}$ or $R_{2,max}$ from the bolt, and they shall be anchored outside the assumed failure cone with an anchorage length of l_{bd} according to EN 1992-1-1 and according to *Figure 9*.

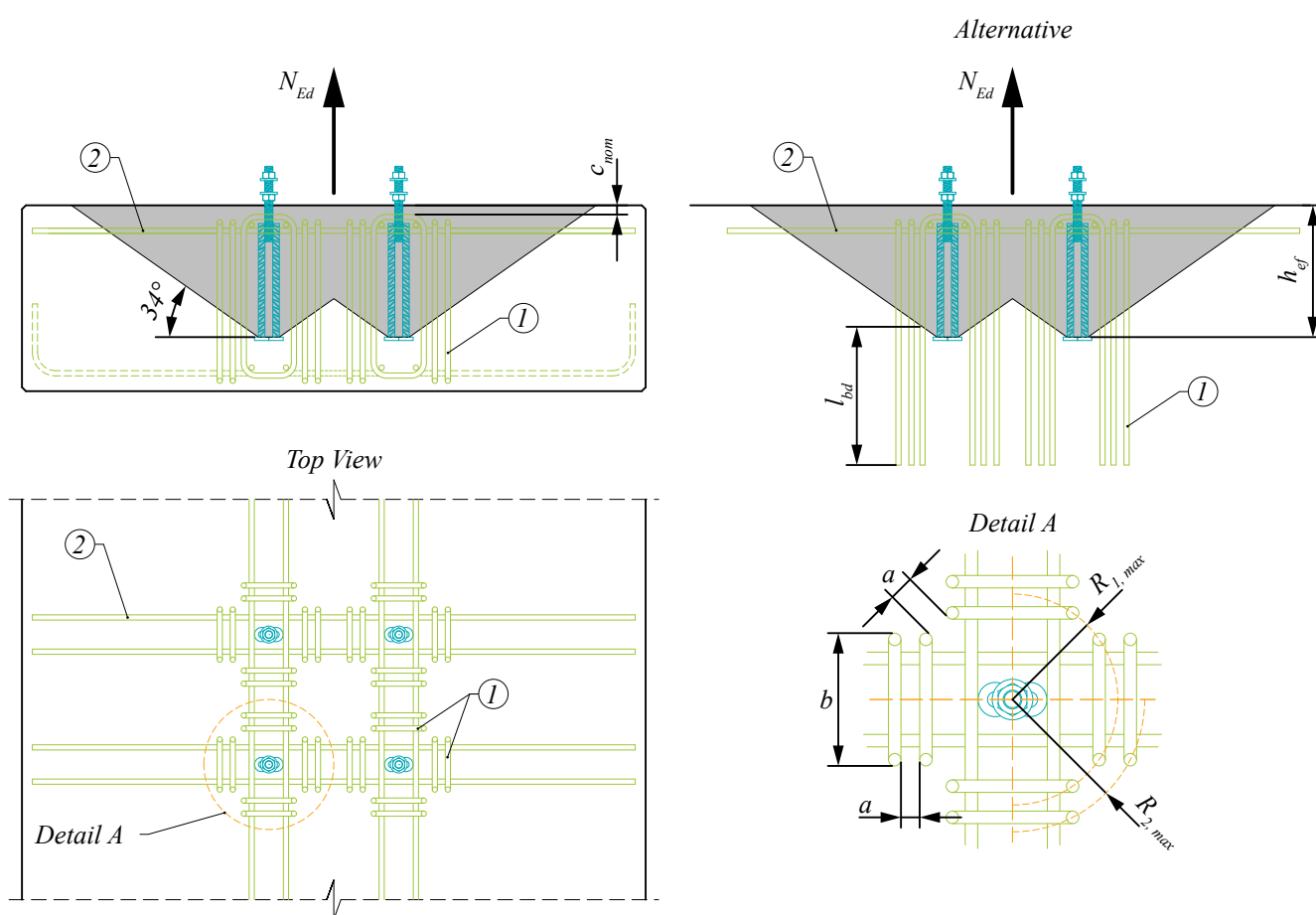

Figure 9. Illustration of detailing of the supplementary reinforcement in the form of stirrups and hairpins.

A2: Splitting reinforcement

If the splitting resistance is exceeded, supplementary side and top face reinforcement near the concrete surface should be provided to resist the splitting forces and to limit splitting cracks. Detailing of reinforcement for PPM® L Anchor Bolts is shown in the following figure. The required quantities of reinforcement bars are given in *Table 11*.

Alternative reinforcement arrangements can be calculated using the Peikko Designer® Column Connection software in accordance with CEN/TS 1992-4-2.

The required cross-section A_s of the splitting reinforcement may be determined as follows:

$$A_s = 0.5 \frac{\sum N_{Ed}}{f_{yk} / \gamma_{Ms,re}} [mm^2] \tag{17}$$

CEN/TS 1992-4-2, Eq. (17)

where

- $\sum N_{Ed}$ = sum of the design tensile forces of the bolts in tension under the design value of the actions
- f_{yk} = nominal yield strength of the reinforcing steel $\leq 500 \text{ N/mm}^2$
- $\gamma_{Ms,re}$ = partial safety factor for steel failure of supplementary reinforcement = 1.15

Table 11. Minimum recommended splitting reinforcement (B500B) per fully loaded anchor bolt.

Anchor Bolt	① + ② [mm ²]	Selected reinforcement
PPM 30 L	344	4 Ø 12
PPM 36 L	501	4 Ø 14
PPM 39 L	599	4 Ø 14
PPM 45 L	801	4 Ø 16
PPM 52 L	1078	6 Ø 16
PPM 60 L	1449	8 Ø 16

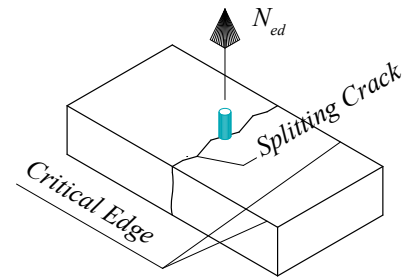

Placement of reinforcement:

- Splitting reinforcement must be evenly placed along the **critical edge(s)*** on the side and top faces of concrete member.
 - * The distance from the edge of the concrete surface to the center of the nearest bolt in tension smaller than $1.8 h_{ef}$
- Bars against splitting must be located inside effective reinforcement zone (i.e. within a distance $\leq 1.5 h_{ef}$ from bolts in tension).
- Pos. ① is the **side-face reinforcement** of the critical edge or edges of the same direction.
- Pos. ② is the **top-face reinforcement** of the critical edge or edges of the same direction.
- **NOTE:** Perpendicular edges should be considered independently (i.e. A_s per direction).

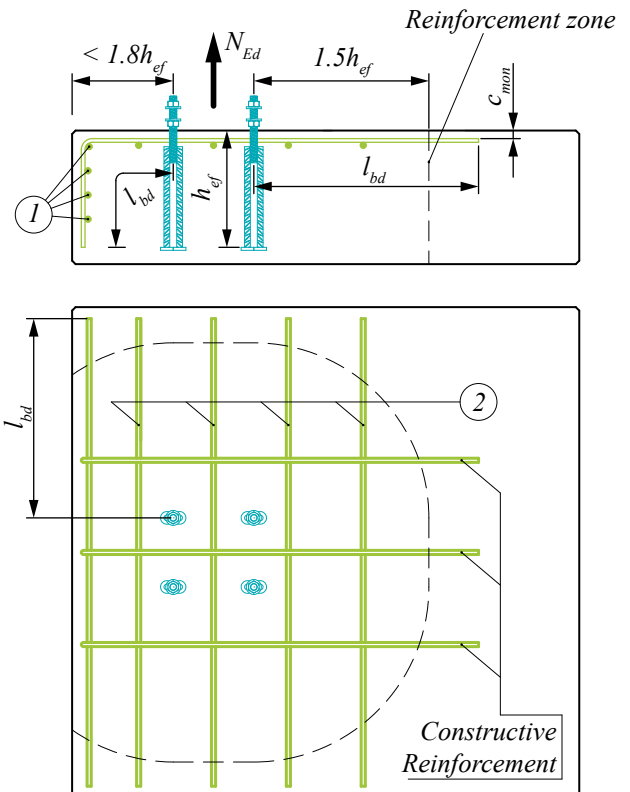

Figure 10. Detail for splitting reinforcement. Example case with one critical edge.

Annex B – Supplementary reinforcement to resist shear load

B1: Edge reinforcement

If the edge cone resistance is exceeded, supplementary reinforcement should be provided based on the corresponding magnitude of the shear force for this edge. The shear force magnitude for the edge under consideration depends on the orientation of the applied load. The requirement and amount of supplementary shear reinforcement for each edge of the concrete member should be checked independently. Detailing of edge reinforcement for PPM® L and P Anchor Bolts is shown in the following figure. The required quantities of U-stirrups are given in *Table 12*. Alternative reinforcement arrangements can be calculated using the Peikko Designer® Column Connection software in accordance with CEN/TS 1992-4-2.

Table 12. Concrete edge reinforcement (B500B) per fully loaded anchor bolt in shear.

Anchor Bolt	U-Stirrups (per bolt) ①	c_l [mm]	c_{nom} [mm]	e_s [mm]	a [mm]
PPM 30	3 \varnothing 14	120	35	170	-
PPM 36	3 \varnothing 16	140	35	170	-
PPM 39	3 \varnothing 16	150	35	180	-
PPM 45	3 + 1 \varnothing 16	160	35	190	28
PPM 52	3 + 2 \varnothing 16	180	35	230	28
PPM 60	3 + 2 \varnothing 16	180	35	270	28

The reinforcement from *Table 12* can be directly applied under the following conditions:

- The distance between the center of gravity of edge reinforcement (i.e. formed of bundle(s), where number of bars in the one bundle is limited to 3) and shear force is equal to or smaller than e_s
- The edge distance is equal to or greater than c_l
- The clear distance between bundles should not be less than (a), requirement according to EN 1992-1-1, section 8.2 (maximum size of aggregate = 16 mm)

It should be noted that the supplementary reinforcement shown in *Table 12* is selected for the edge perpendicular to the applied load, which is the least favorable case.

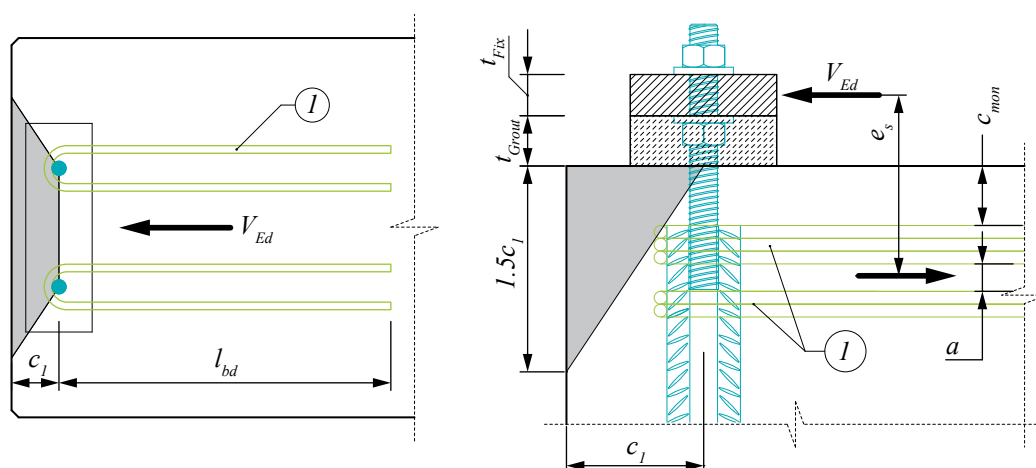

Figure 11. Illustration of detailing of the supplementary reinforcement in the form of loops.

NOTE: In *Figure 11* it is assumed that the edges of the concrete member parallel to the applied load have sufficient resistance without supplementary reinforcement.

Annex C – Supplementary reinforcement to resist compression load

C1: Concrete cone reinforcement for punching

If the punching resistance under the head of the anchor bolt is exceeded, supplementary reinforcement should be provided. Detailing of supplementary reinforcement for PPM® L Anchor Bolts is shown in following figure. The required quantities of stirrups are given in *Table 13*. Reinforcement may be omitted if the concrete thickness h under the bolt's head is equal to or greater than h_{req} (see *Figure 12*).

Table 13. Reinforcing the cone failure under the bolt. Reinforcement steel grade: B500B.

Anchor Bolt	h_{req} [mm]	A_s [mm ²]	Stirrups (per bolt) ①
PPM 30 L	90	199	2 Ø 8
PPM 36 L	85	205	2 Ø 10
PPM 39 L	75	171	2 Ø 8
PPM 45 L	50	122	2 Ø 8
PPM 52 L	105	373	2 Ø 12
PPM 60 L	55	175	2 Ø 8

NOTE: Pre-calculated h_{req} thicknesses are relevant only for cases where the punching cone under the bolt's head is not limited by adjacent cones or the edges of the base structure (see *Figure 12*). The inclination angle of stress cone is 45°.

The reinforcement from *Table 13* can be directly applied under the following conditions:

- The concrete strength class of base structure is equal to or greater than C25/30 (good bond conditions)
- The nominal maximum aggregate size in concrete is equal to or smaller than 16 mm
- Stirrups are located inside the stress cone and they shall be anchored outside the assumed failure cone with an anchorage length of l_{bd} according to EN 1992-1-1 and according to *Figure 12*.

It should be noted that punching reinforcement, if in form of closed stirrups, may be used as hanger reinforcement for tension.

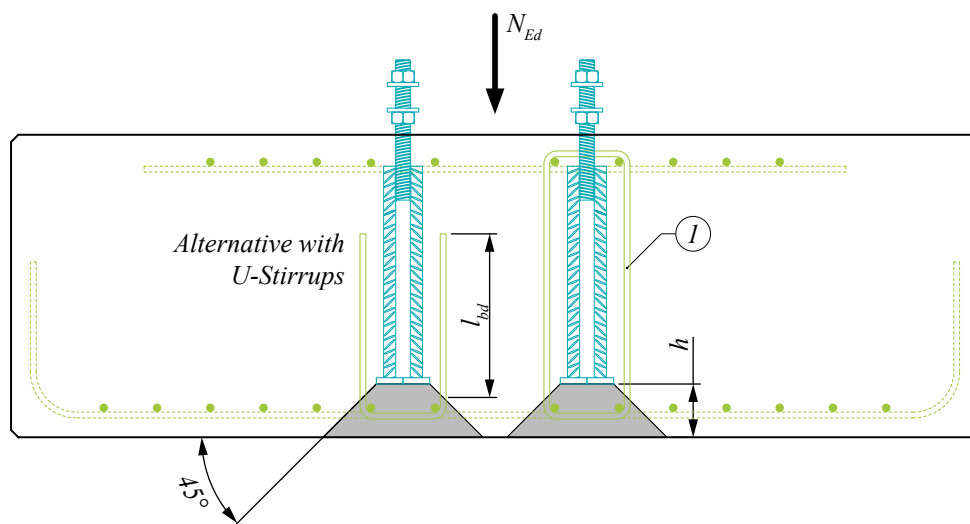

Figure 12. Reinforcing the conical fracture under the bolt.

C2: Partially loaded areas, Splitting reinforcement

If the compression resistance of the base structure is exceeded, local crushing should be considered. For that reason, the concrete strength class of the lower column in the column-to-column connections should be at least the same as that used in the upper column. Local crushing can be prevented by expanding the base structure by dimension Δ (see Figure 13). In addition, splitting reinforcement should be provided to resist transverse tension forces in the base structure. The stirrups should be distributed uniformly in the direction of the tension force over the height h , where compression trajectories are curved. In the absence of better information, height h can be taken as 2Δ .

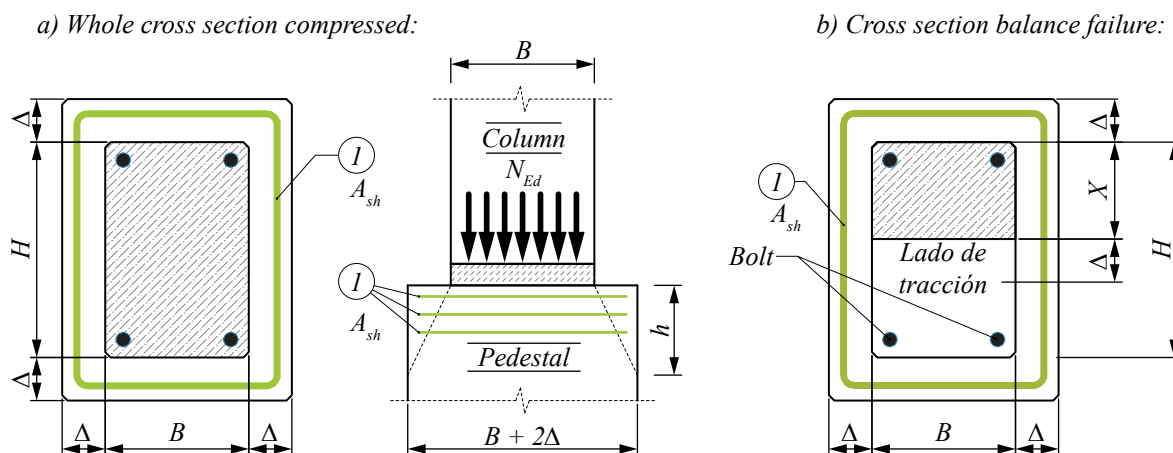

Figure 13. Column connection with two different size sections. Splitting reinforcement in base column.

Table 14. The expansion Δ of base structure and required splitting stirrups (B500B).

Concrete Grade (Column)	Concrete Grade (Base Column)	a) Whole cross section compressed Δ [mm]	b) The bolts of the tension side yield (balance failure) Δ [mm]	Required reinforcement area Stirrups with 2-cuts A_{sh} [mm ²]
C30/37	C25/30	$\Delta = 0.10 \times H$	$\Delta = 0.06 \times H$	$A_{sh} = B \times H/933$
C35/45	C25/30	$\Delta = 0.20 \times H$	$\Delta = 0.12 \times H$	$A_{sh} = B \times H/474$
C40/50	C25/30	$\Delta = 0.30 \times H$	$\Delta = 0.18 \times H$	$A_{sh} = B \times H/320$
C50/60	C35/45	$\Delta = 0.21 \times H$	$\Delta = 0.13 \times H$	$A_{sh} = B \times H/317$
C60/75	C35/45	$\Delta = 0.36 \times H$	$\Delta = 0.22 \times H$	$A_{sh} = B \times H/193$

DESIGN EXAMPLE

A concrete 400 [mm] × 400 [mm] column (C30/37) bears on a base column (C20/25). Determine the minimum cross section and required splitting reinforcement of the base structure to resist the maximum compression force applied from the supported column.

Loading Situation: Column under uniaxial compression without bending moment.

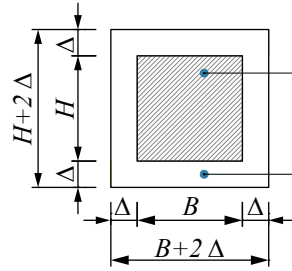

$$A_{c0} \text{ Column: } f_{cd,c} = 20.0 \text{ N/mm}^2$$

$$A_{c1} \text{ Base: } f_{cd,b} = 13.33 \text{ N/mm}^2$$

The concentrated resistance force of the partially loaded area:

$$F_{Rdu} = A_{c0} \cdot f_{cd,b} \cdot \sqrt{\frac{A_{c1}}{A_{c0}}} \leq 3.0 \cdot f_{cd,b} \cdot A_{c0}$$

EN 1992-1-1, Eq. (6.63)

where

- A_{c0} is the loaded area
- A_{c1} is the maximum design distribution area with a similar shape to A_{c0}
- $f_{cd,b}$ is the design compressive strength of base structure

Substituting in Eq. (6.63):

$$\begin{aligned} A_{c0} &= B \cdot H = 400 \cdot 400 = 160000 \text{ mm}^2 \\ A_{c1} &= (B + 2 \cdot \Delta) \cdot (H + 2 \cdot \Delta) = (400 + 2 \cdot \Delta) \cdot (400 + 2 \cdot \Delta) = (400 + 2 \cdot \Delta)^2 \\ F_{Rdu} &= \text{maximum applied force (i.e. ultimate strength of an axially loaded column)} \\ &= A_{c0} \cdot f_{cd,c} = B \cdot H \cdot f_{cd,c} = 160000 \cdot 20 = 3200000 \text{ N} = 3200 \text{ kN} \end{aligned}$$

where

- $f_{cd,c}$ is the design compressive strength of column

Solving this quadratic equation:

$$\begin{aligned} B \cdot H \cdot f_{cd,c} &= B \cdot H \cdot f_{cd,b} \cdot \sqrt{\frac{(B + 2 \cdot \Delta) \cdot (H + 2 \cdot \Delta)}{B \cdot H}} \\ \Delta &= 100 \text{ mm} \end{aligned}$$

Minimum cross-section of base column:

$$(B + 2 \cdot \Delta) \times (H + 2 \cdot \Delta) = 600 \text{ [mm]} \cdot 600 \text{ [mm]}$$

Splitting force (according to EN 1992-1-1, section 6.5):

$$F_{sp} = 0.25 \cdot F_{Rdu} \cdot \left(1 - \frac{B}{B + 2\Delta}\right) = 0.25 \cdot 3200 \cdot \left(1 - \frac{400}{600}\right) = 266.7 \text{ kN}$$

Required splitting reinforcement area (2-cuts, B500B):

$$A_{sp} = \frac{F_{sp}}{2 \cdot \frac{f_{yk}}{\gamma_s}} = \frac{266700}{2 \cdot \frac{500}{1.15}} = 306.7 \text{ mm}^2$$

where

- f_{yk} = characteristic yield strength of reinforcement
- γ_s = partial safety factor for reinforcement

Selected stirrups: 7Ø8 or 4Ø10

Annex D – Transverse reinforcement in the lap zone

Long PPM® P Anchor Bolts are designed for use in lap splices with the main reinforcement of the base structure. The base structure must be reinforced with at least the same cross section area of longitudinal bars corresponding to the bolts. Adequate transverse reinforcement $\sum A_{st}$ should be provided in the lap zone (see Figure 14). The required quantities of stirrups are given in Table 15. Alternative reinforcement arrangements can be calculated using the Peikko Designer® Column Connection software.

Table 15. Reinforcement for lap splices. Reinforcement steel grade: B500B.

Anchor Bolt	Total amount of stirrups ①	l_0 [mm]
PPM 30 P	5 + 5 $\emptyset 8$	1485
PPM 36 P	4 + 4 $\emptyset 8$	1230
PPM 39 P	5 + 5 $\emptyset 8$	1575
PPM 45 P	5 + 5 $\emptyset 10$	1575
PPM 52 P	5 + 5 $\emptyset 10$	1650
PPM 60 P	6 + 6 $\emptyset 12$	2160

The reinforcement from Table 15 can be directly applied under the following conditions:

- The concrete strength class of base structure is equal to or greater than C25/30 (good bond conditions)
- The nominal maximum aggregate size in concrete is equal to or smaller than 16 mm
- The bolts are loaded in tension
- For anchor groups with more than 4 bolts extra internal ties should be provided.

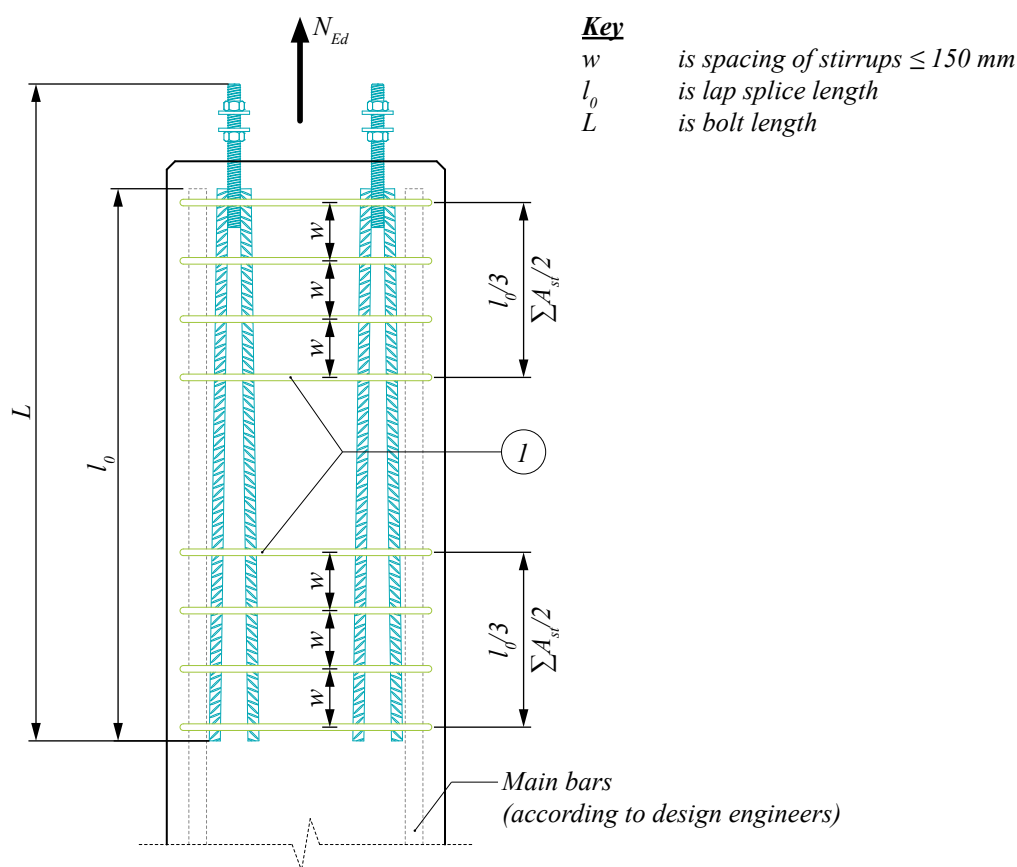
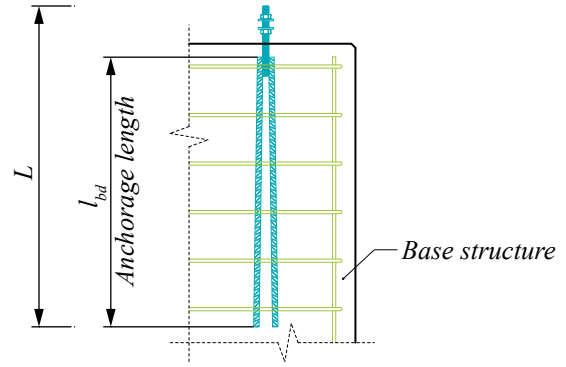

Figure 14. Transverse reinforcement for lapped splices. Detail of reinforcement when bars in tension.

Annex E – Alternative use of PPM® P High-Strength Anchor Bolts

1. PPM® P Anchor Bolts as alternative to lap splices can be anchored as longitudinal reinforcement by providing sufficient tension/compression development length. It should be noted that this solution might require additional verifications and reinforcement for the base structure. The design anchorage length l_{bd} to anchor the force N_{Ed} acting on a bolt must be checked in accordance with EN 1992-1-1, section 8.4.



2. PPM® P Anchor Bolts can be also installed in shallow structures with limited thickness by bending them. The minimum mandrel diameter $\varnothing_{m,min}$ must be checked for each individual case (according to EN 1992-1-1, section 8.3) to avoid bending cracks in the anchor bolt and to avoid failure of the concrete inside the bend.

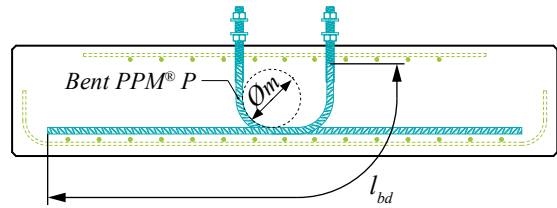

Bent anchor bolts can be manufactured and delivered according to specification.

3. If requested, extra-long PPM® P Anchor Bolts are available for structural solutions such as column-to-column connections through the slab or beam. Where l_0 is the design lap length in accordance with EN 1992-1-1, section 8.7.3.

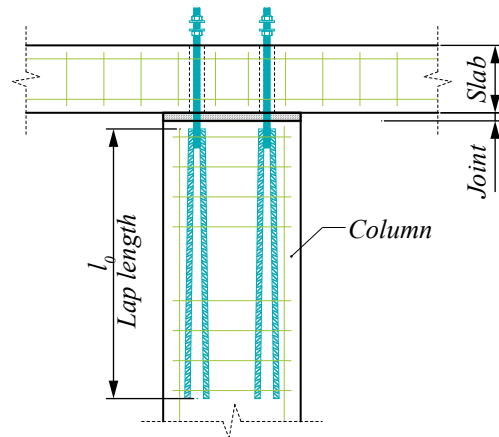

Ordering non-standard PPM® P Anchor Bolts:

All dimensions in [mm]

1. Straight PPM® P Anchor Bolt \Rightarrow PPM(*)P – L
Example 1: PPM30P – 2000
2. Bent PPM® P Anchor Bolt \Rightarrow PPM(*)P – L – Bent(α) – B
Example 2: \Rightarrow PPM30P – 2000 – Bent90 – 500
Example 3: \Rightarrow PPM30P – 2500 – Bent90 – 700

where

- * is the size of the bolt
- L is the total length of the bolt
- α is the angle of bend [degrees]
- B is the position of bend

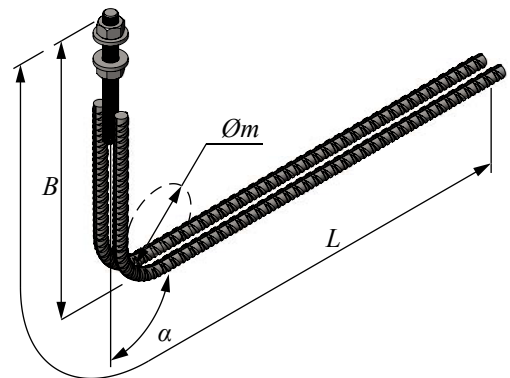

Annex F – Alternative means to transfer shear load

There are two principal ways of transferring shear force from columns into the base structure:

- By anchor bolt shear resistance (see *Table 6*)
- By friction resistance between the base plate and grout:

$$F_{f,Rd} = \mu \cdot N_{Ed}$$

where

μ is the friction coefficient between the base plate and grout = 0.20 (without additional tests)

N_{Ed} is the design value of the normal compressive force in the column

NOTE: If the column is loaded with tensile axial force, $\mu \cdot N_{Ed} = 0$

Alternative ways used in resisting large shear forces:

- Shear dowel (see *Figure 15a*)
- Embedding the column in the base structure (see *Figure 15b*)
- Transferring the force to the floor slab using hairpin bars (see *Figure 15c*).

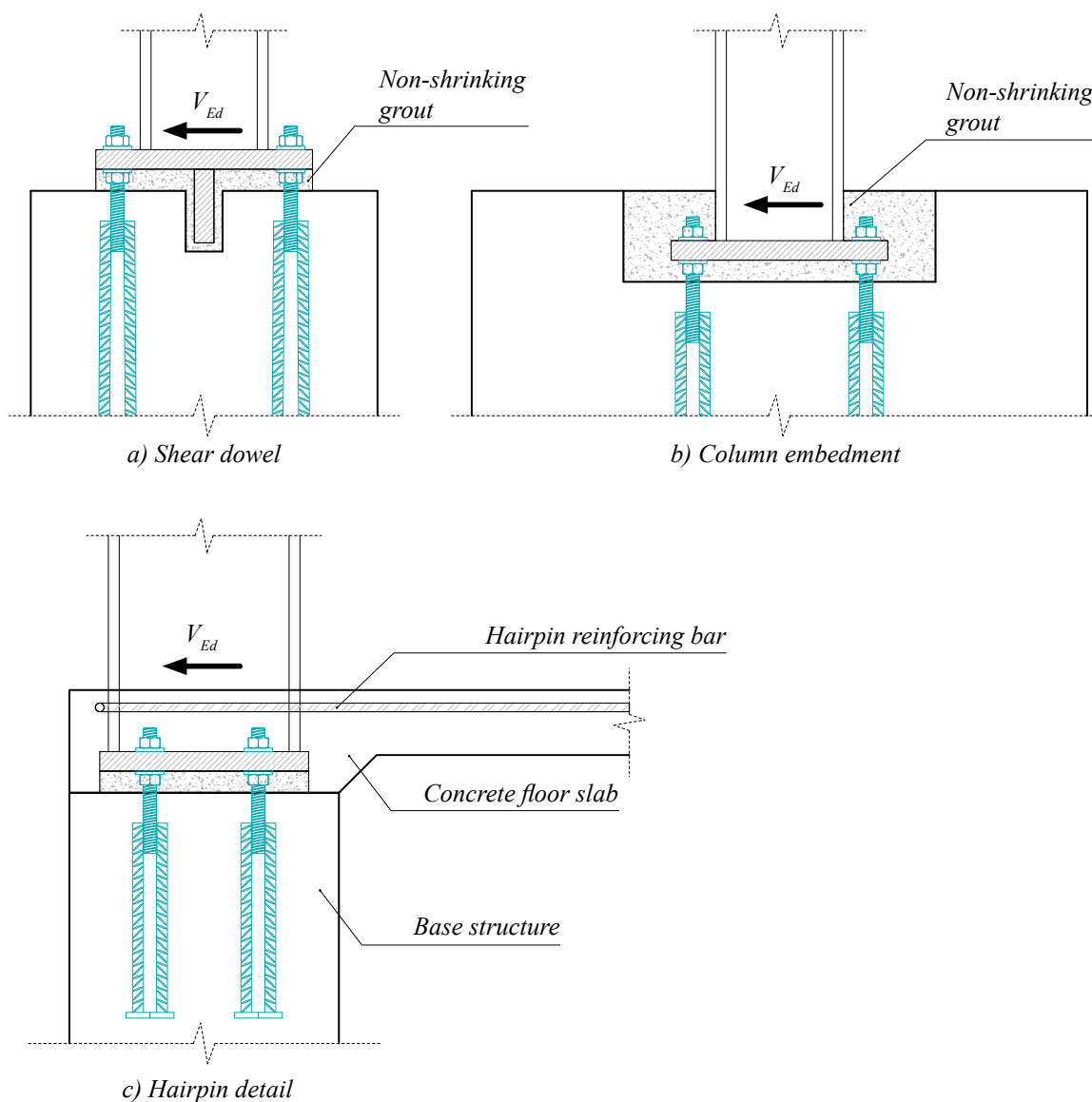

Figure 15. Details of alternative means of transferring shear load.

Installation of PPM® High-Strength Anchor Bolts

Identification of the product

PPM® Anchor Bolts are available in standard models (30, 36, 39, 45, 52 and 60) analogous to the metric thread size of the bolt. The model of anchor bolt can be identified by the name in the label on the product and the color of the product.

Forming a bolt group

Bolts are collected into bolt groups using the PPL Installation Template. The installation template enables bolt groups to be centralized on the horizontal plane in exactly the right place and easily adjusted to the correct casting level.

PPM® Anchor Bolt color identification.

Anchor Bolt	Thread diameter [mm]	Color code	Installation Template
PPM 30	30	Black	PPL 30
PPM 36	36	Red	PPL 36
PPM 39	39	Brown	PPL 39
PPM 45	45	Purple	PPL 45
PPM 52	52	White	PPL 52
PPM 60	60	-	PPL 60

The PPL Installation Template is a steel plate. Anchor Bolts are fixed through the holes on the template with nuts and washers. The PPL installation plate has alignment marks for accurate positioning of the anchor bolt group. Anchor bolts also have center marks on the top of each bolt for alternative positioning methods.

To prevent displacement during the concreting process, the template should be fixed securely to the supporting base by its fixing recesses at the sides. Concrete can be poured easily through the hole in the middle of the template. After casting, the installation template is detached and can be reused.



Ordering PPL Installation Templates

When PPL Installation Templates are ordered the thread diameter of bolts, the number of bolts and the center-to-center dimensions must be specified.

Examples of installation plates:

- | | |
|--|--|
| 1. PPL39-4 360×360: | 4 pieces M39 bolts in square form. |
| 2. PPL39-4 500×400: | 4 pieces M39 bolts in rectangular form. |
| 3. PPL30-6 280×(190+190): | 6 pieces M30 bolts rectangular form. |
| 4. PPL30-8 (190+190)×(190+190): | 8 pieces M30 bolts in the form of a square. |
| 5. PPL30-3 300×300: | 3 pieces M30 bolts in the form of rectangular triangles. |
| 6. PPL24-8 D400: | 8 pieces M24 bolts in the form of circles with diameter of 400 mm. |

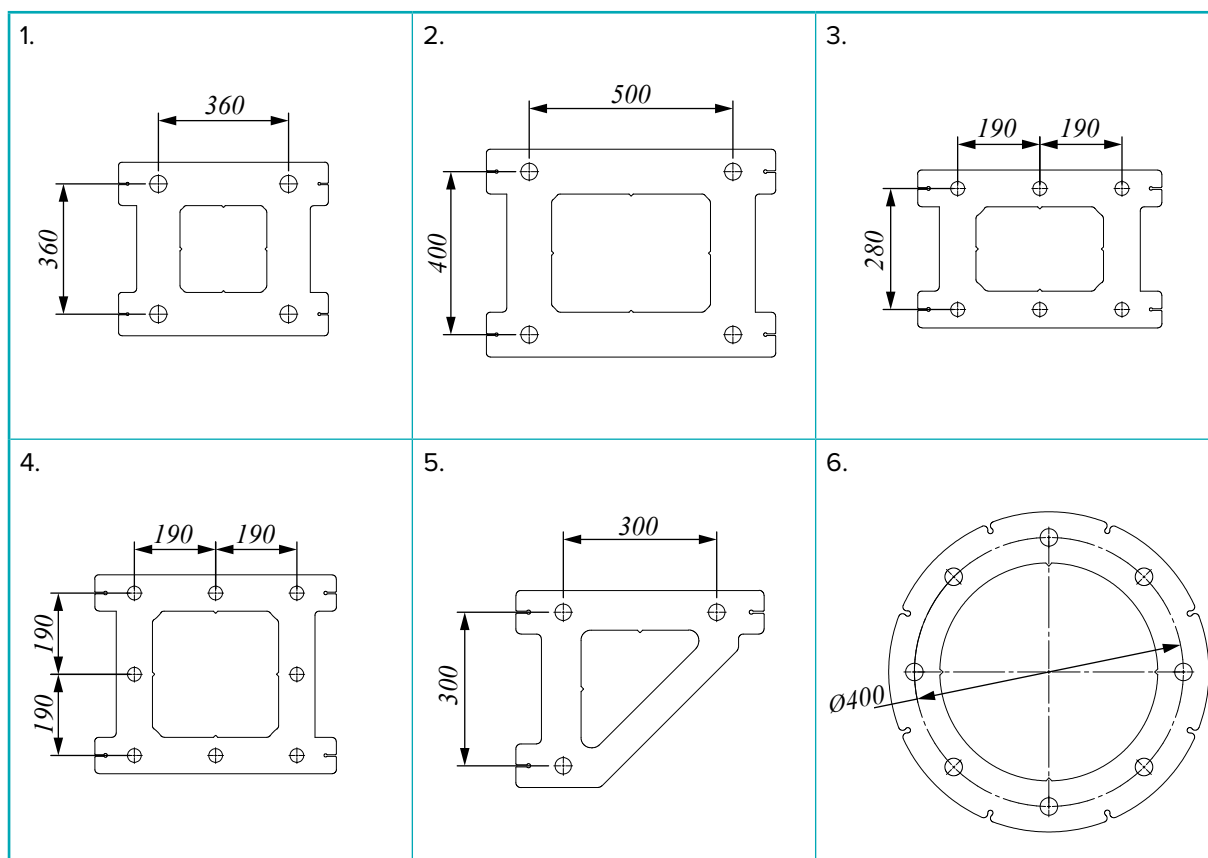

PPL Installation Templates can also be manufactured according to drawings that present the location of the bolts and thread diameters. It should be noted that many heavy bolts in a one group might require extra lifting and handling support to prevent template from bending. If needed thicker plate or additional stiffeners can be used.

Bolt installation and installation tolerances

The bolts are installed to the height level according to dimension h_b given in table below. This will cover base plate thicknesses t_{Fix} or thinner. The height level is measured from the surface of concrete, and the level tolerance is ± 20 mm. Each anchor bolt includes a marking of the anchorage depth.

Installation tolerances and the anchor bolt's protrusion from the concrete.

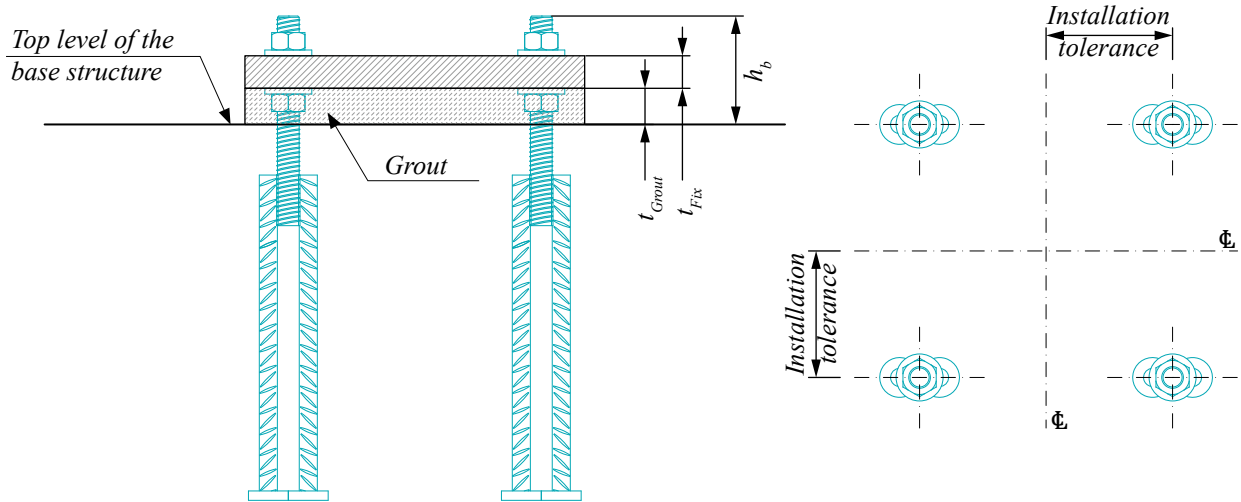

Anchor Bolt	PPM 30	PPM 36	PPM 39	PPM 45	PPM 52	PPM 60
Thickness of grouting t_{Grout} [mm]	50	55	60	65	70	80
Thickness of base plate t_{Fix} [mm]	≤ 45	≤ 50	≤ 60	≤ 60	≤ 80	≤ 85
Protrusion of the bolt h_b [mm] suitable for PEC® and for general applications	155	170	190	200	235	260
Protrusion of the bolt h_b [mm] suitable for BOLDA®	135	160	175	190	220	---
Installation tolerance for the bolt [mm]	± 3	± 4	± 4	± 4	± 5	± 5

Bending the bolts

The anchor bars of PPM® Bolts are made of B500B ribbed reinforcement steel. Bending of anchor bars must be done in accordance with EN 1992-1-1. See Annex E of this manual with application examples.

Welding the bolts

Welding of the bolts should be avoided, although all materials used in PPM® Anchor Bolts are weldable (except the nuts). Requirements and instructions of standard EN 17660-1: *Welding of reinforcing steel, Part 1: load bearing welding joints*, shall be taken into account when welding anchor bars.

Existing buildings

Where placing anchor bolts adjacent to walls or other obstructions, construction sequences should be considered. It is necessary to check that the erector will have enough access to tighten the nuts. If special setting is required, please contact Peikko Technical Support.

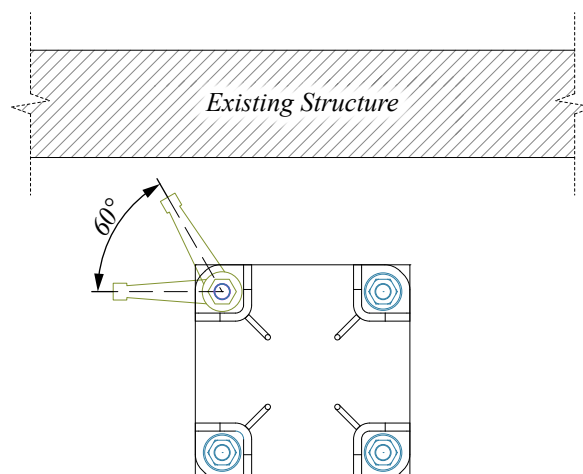

Erection of the attachment

Before erecting the attachment, the upper nuts and washers are removed from the anchor bolts. The lower leveling nuts and washers are adjusted to the correct level. The attachment is erected directly on the pre-leveled washers and nuts.

An alternative method is to place shims between anchor bolts and adjust them to the proper level. The lower leveling nuts must be leveled at least 5 mm under the top level of shims to ensure that the attachment will rest first on the shims.



INSTALLING

Securing the connection

The upper nuts and washers are screwed onto the bolts and the attachment is aligned in the vertical position using leveling nuts. It is practical to use two theodolites from different directions to ensure verticality. The nuts are tightened at least to the minimum torque given in the table below. Adequate torque can be achieved typically by 10 – 15 impacts of a slogging ring wrench (DIN 7444) or open-ended slogging wrench (DIN 133) and a 1.5 kg sledgehammer.

Recommended minimum T_{min} torque values of nuts.

Anchor Bolt	T_{min} [Nm]	Size of the slogging wrench
PPM 30	250	46 mm
PPM 36	300	55 mm
PPM 39	350	60 mm
PPM 45	400	70 mm
PPM 52	450	80 mm
PPM 60	500	90 mm



Grouting the joint

Before loading the attachment with any other structures the joint must be grouted following the grout supplier's instructions. The grouting must be non-shrinking and have a strength according to the plans.

To avoid air being trapped in the joint, it is recommended that grout should be poured from one side only.

Grouting formwork is made so that adequate concrete cover for anchor bolts is achieved.



Instructions for controlling bolt installation

Before casting:

- Ensure that the right PPL Installation Template is used (axial distances, thread size)
- Verify the location of the bolt group
- Ensure that the reinforcement required by the bolts has been correctly installed
- Ensure that the bolts are at the correct level
- Ensure that the installation plate and bolt group are not rotated
- Ensure that the bolt group is fixed in such a way that no movement can occur during casting.

After casting:

- Ensure that the location of the bolt group is within the allowance for tolerance. Greater variations must be reported to the structural designer
- Protect the thread until the erection of the attachment (tape, plastic tube, etc.)
- Protect the bolts in construction phase for potential traffic risks on the building site e.g. vehicles, excavators.

Instructions for controlling attachment installation

The joints, including all working phases such as storing, lifting, handling and installing, must be made according to the installation plan drafted by the structural designer. If needed, Peikko's technical support can provide advice.

Check the following:

- The installation order
- Supports and bracing during installation
- Instructions for tightening the nuts
- Instructions for joint casting.

Revisions

Version: PEIKKO GROUP 01/2021. Revision: 002

- Protrusion values of the bolt h_b suitable for BOLDA® added
- Updated to latest layout style.

Version: PEIKKO GROUP 05/2015. Revision: 001*

- New cover design for 2018 added.

Resources

DESIGN TOOLS

Use our powerful software every day to make your work faster, easier and more reliable. Peikko design tools include design software, 3D components for modeling programs, installation instructions, technical manuals and product approvals of Peikko's products.

peikko.com/design-tools

TECHNICAL SUPPORT

Our technical support teams around the world are available to assist you with all of your questions regarding design, installation etc.

peikko.com/technical-support

APPROVALS

Approvals, certificates and documents related to CE-marking (DoP, DoC) can be found on our websites under each products' product page.

peikko.com/products

EPDS AND MANAGEMENT SYSTEM CERTIFICATES

Environmental Product Declarations and management system certificates can be found at the quality section of our websites.

peikko.com/qehs

