

S&B Brandmanschett

TECHNICAL DATA SHEET

S&B Brandmanschett are designed to maintain the fire resistance of floor and walls when penetrated by plastic pipes and metal and plastic pipes with continuous combustible insulation. Under fire conditions the intumescent filler expands to many times its original thickness exerting pressure on the softening pipe and/or insulation closing the opening with a dense block of fire resistant char.

Description

The collars are manufactured using durable stainless steel in a simple to use, one-piece wraparound design with a slid through/fold back tab fixing.

The height of the collars is just 30mm or 45mm for larger pipes enabling the collars to be used where space is tight and access difficult.

Performance

S&B Brandmanschett are tested to the latest European requirements for applications in walls and floors.

- Fire Classification to EN 13501-2 and CE Mark (ETA 14/0060)
- Flexible Walls (stud partitions) or rigid walls (masonry, concrete) of 100mm minimum thickness
- Rigid (concrete) floors of 150mm minimum thickness
- All testing undertaken using uncapped pipes (U/U) with specification applicable to all types of plastic pipe end uses including ventilation pipes
- Mechanical and durability testing to ETAG 026-2; Y2 (internal use within full ambient temperature range inclusive of temperatures less than 0°C)
- Third party product certification with UL International (Certificate # UL-EU-00513)

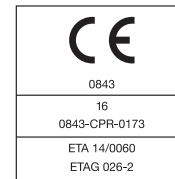

S&B Brandmanschett in partitions or masonry/concrete walls of minimum thickness 100mm

Penetrating service	Pipe outside diameter (mm)	Pipe wall thickness (mm)	Collar size	Fire performance (mins)	
				Integrity (E)	Integrity & insulation (EI)
PVC-U pipes (EN 1329-1, EN 1452-2, EN 1453-1)	20-40	3.0	Select nearest collar size equal to or greater than pipe outside diameter (see pipe collar dimensions table)	120	120
	41-82	3.2		120	120
	83-110	2.7-6.6		120	90
	125-160	2.5-9.5		120	120
PE pipes (EN 1519-1, EN 12201-2, EN1266-1) ABS pipes (EN 1455-1) SAN+PVC pipes (EN 1565-1)	20-40	3.8		120	120
	41-50	4.6		120	120
	51-75	6.8		120	90
	76-110	6.6		120	90
	111-160	14.6	60	60	

S&B Brandmanschett in masonry/concrete walls of minimum thickness 100mm

Penetrating service	Pipe outside diameter (mm)	Pipe wall thickness (mm)	Collar size	Fire performance (mins)	
				Integrity (E)	Integrity & insulation (EI)
PVC-U pipes (EN 1329-1, EN 1452-2, EN 1453-1)	110	1.8–4.2	Select nearest collar size equal to or greater than pipe outside diameter (see pipe collar dimensions table)	240	240
	111–160	2.5		240	240
PE pipes (EN 1519-1, EN 12201-2, EN1266-1) ABS pipes (EN 1455-1) SAN+PVC pipes (EN 1565-1)	160	6.2		240	240
	80	N/A		240	240
Nitrile rubber insulated multi-tube (PE) drinks python	80	N/A		240	240
Steel pipes + 13mm continuous combustible nitrile rubber insulation	48	1.5–14.2		240	180
Steel pipes + 19mm continuous combustible nitrile rubber insulation	114	2.0–14.2	240	120	

S&B Brandmanschett in concrete floors of minimum thickness 150mm

Penetrating service	Pipe outside diameter (mm)	Pipe wall thickness (mm)	Collar size	Fire performance (mins)	
				Integrity (E)	Integrity & insulation (EI)
PVC-U pipes (EN 1329-1, EN 1452-2, EN 1453-1)	20–40	3.0	Select nearest collar size equal to or greater than pipe outside diameter (see pipe collar dimensions table)	240	240
	41–82	3.2		120	120
	83–110	1.8		180	180
	83–110	1.9–10		120	120
	111–160	2.5		180	180
	111–160	2.6–9.5		90	90
PE pipes (EN 1519-1, EN 12201-2, EN1266-1) ABS pipes (EN 1455-1) SAN+PVC pipes (EN 1565-1)	20–40	3.7		180	180
	41–50	11.6		120	120
	51–90	5.1		180	180
	91–110	4.2		180	180
	111–160	6.2		120	120
	20–40	3.7		240	240
PP (DIN 8077/8078, EN ISO 15494)	41–50	1.8	240	240	
	41–50	1.9–2.8	120	120	
	51–75	1.9	180	180	
	76–90	2.2	240	240	
	91–110	2.7	240	240	
	20–40	3.7	240	240	
Nitrile rubber insulated multi-tube (PE) drinks python	80	N/A	240	240	
Steel pipes + 13mm continuous combustible nitrile rubber insulation	48	1.5–14.2	120	120	
Steel pipes + 19mm continuous combustible nitrile rubber insulation	114	2.0–14.2	60	60	

S&B Brandmanschett used in conjunction with minimum 50mm Brennix Brandskyddsmassa supported on 50mm thick 140kg/m³ stone mineral wool permanent shuttering

Penetrating service	Pipe outside diameter (mm)	Pipe wall thickness (mm)	Collar size	Fire performance (mins)		
				Integrity (E)	Integrity & insulation (EI)	
PVC-U pipes (EN 1329-1, EN 1452-2, EN 1453-1)	20-40	3.0	Select nearest collar size equal to or greater than pipe outside diameter (see pipe collar dimensions table)	120	120	
	41-82	3.2		120	120	
	83-110	1.8		120	120	
	83-110	1.9-10		120	120	
	111-160	2.5		120	120	
	111-160	2.6-9.5		90	90	
PE pipes (EN 1519-1, EN 12201-2, EN1266-1)	20-40	3.7		180	180	
	41-50	11.6		120	120	
	ABS pipes (EN 1455-1)	51-90		5.1	120	120
		SAN+PVC pipes (EN 1565-1)		91-110	4.2	120
	111-160			6.2	120	120
PP (DIN 8077/8078, EN ISO 15494)	20-40	3.7		240	240	
	41-50	1.8	240	240		
	41-50	1.9-2.8	120	120		
	51-75	1.9	120	120		
	76-90	2.2	120	120		
	91-110	2.7	120	120		
	Nitrile rubber insulated multi-tube (PE) drinks python	80	N/A	120	120	
Steel pipes + 13mm continuous combustible nitrile rubber insulation	48	1.5-14.2	120	120		
Steel pipes + 19mm continuous combustible nitrile rubber insulation	114	2.0-14.2	60	60		

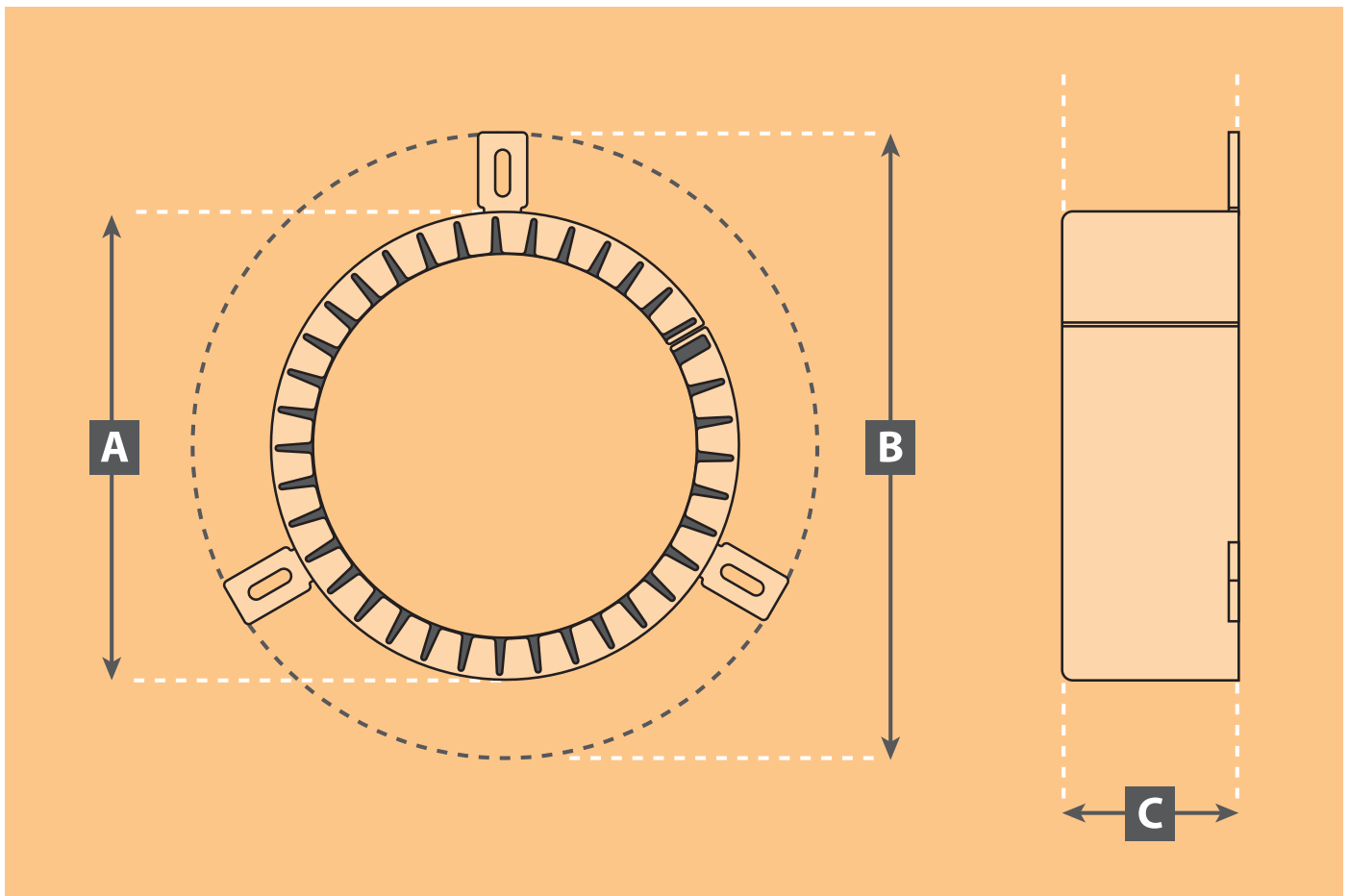

S&B Brandmanschett dimensions (nominal) and packaging data

Pipe size (mm)	Outside diameter (mm) A	Diameter including fixing lugs (mm) B	Height (mm) C	Number of fixing lugs	Pipe collar weight (kg)	Units per box
40	54	104	30	2	0.06	80
55	69	119	30	2	0.08	48
65	79	129	30	2	0.10	48
75	89	139	30	2	0.10	72
82	96	146	30	3	0.10	63
90	112	162	30	3	0.18	72
110	132	182	30	3	0.22	60
125	147	197	45	3	0.34	33
140	174	224	45	3	0.37	16
160	194	244	45	3	0.70	18

Slotted opening in fixing lugs is 6mm wide and suitable for use with M5 steel fixings.

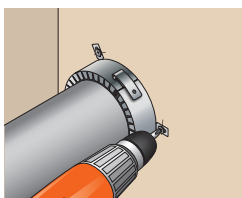
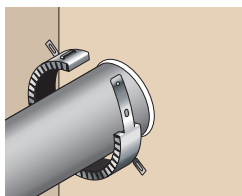
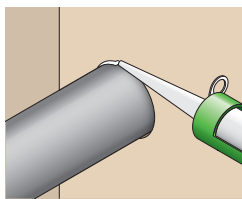
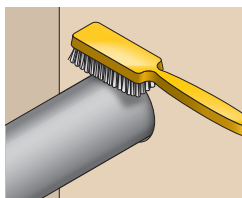
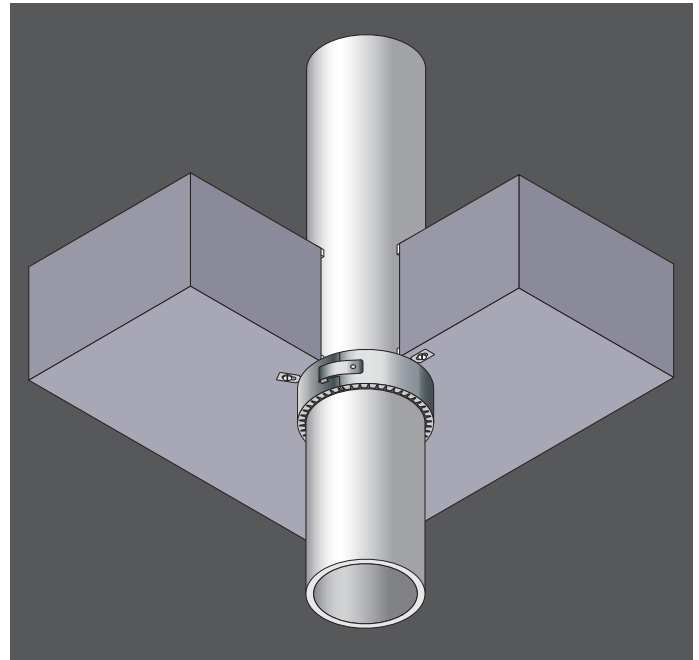
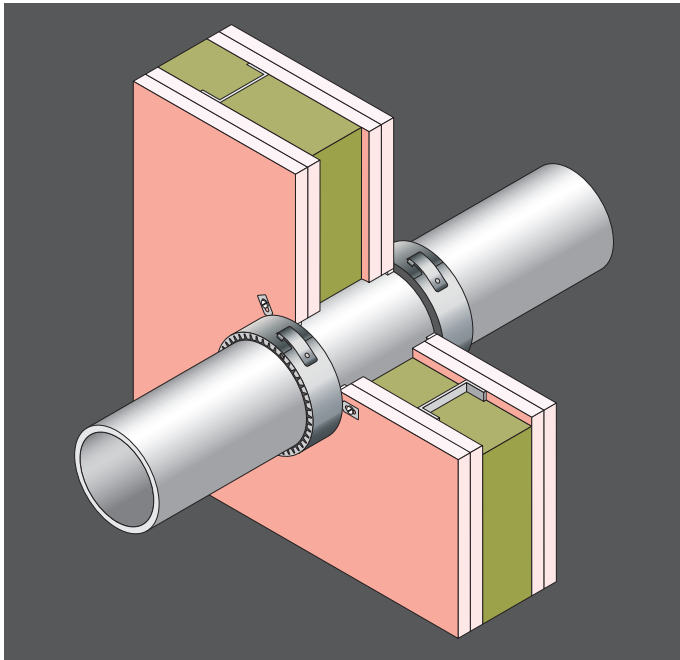

Installation

- Ensure contact surface for collar is flat and free from obstructions
- Clean away all dirt and loose materials
- Seal any gaps around the pipe using Brennix Brandfog Fire Resistant & Acoustic Sealant or Brennix Brandskyddsassa to maximise acoustic and cold smoke seal performance
- Select suitable steel fixings which do not rely on plastic components for grip (i.e. 50mm x 8mm steel masonry screws, 50mm minimum long expandable steel bolts, or steel cavity fixings)
- Where holes for fixings need to be pre-drilled, place the collar around the pipe and mark the fixing positions on the wall/floor through the fixing tabs before removing and drilling suitably sized holes
- Fix the collar around the pipe using the slide through/fold back tab and position against the surface aligning the holes in the fixing tabs with the pre-drilled holes as appropriate
- Complete the mechanical fixing to the surface using the selected steel fixings

NOTE: Collars should be fixed to both sides of walls and to the underside of floors only.

End use considerations

Whilst S&B Brandmanschett are intended for internal use, they have been subjected to mechanical and durability testing and the intumescent components are not affected by moisture. The collars are also suitable for use at temperatures below 0°C.

Maintenance

No routine maintenance is required although periodic inspection for possible damage is recommended.

Storage

It is recommended to store in dry conditions between 5°C and 40°C.

Shelf life

Shelf life is unlimited when stored under recommended storage conditions.

Health and safety

Please refer to safety data sheet before use.

Since the product is applied under circumstances beyond our control, Stål & Brandteknik AB can accept no direct or consequential liability whether in contract or in tort, for the interpretations of such recommendations and reserves the right to modify the recommendations as necessary.