

- ⓐ Attachement point for personal fall protection
- ⓓ Anschlagpunkt für persönliche Sicherheitsausrüstung

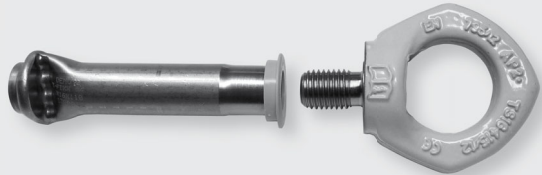

Assembly Instructions • Montageanleitung

HALFEN Attachment point for fixing PSA personal fall protection according to DIN EN 795

A single personal fall protection anchor point (PSA) consists of an approved, DEMU T-FIXX®, stainless steel fixing anchor, an identification cap and an approved eye-bolt.

The suitability of the approved DEMU T-FIXX® fixing anchor as a personal fall protection anchor point for a maximum of two people was confirmed in a DGUV* test based on CEN/TS 16415.

DEMU T-FIXX® M16, A4

Separately available: Suitable eye-bolt, RUD PSA INOX STAR M16

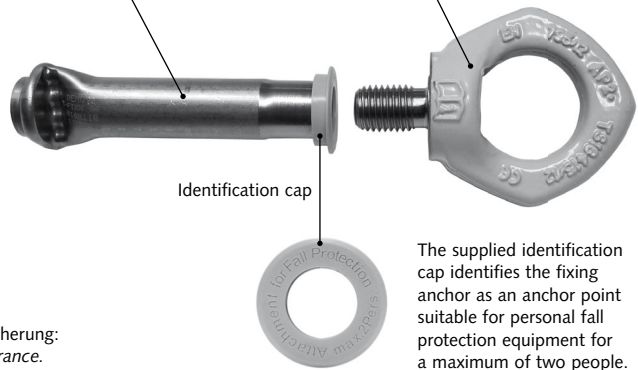

The supplied identification cap identifies the fixing anchor as an anchor point suitable for personal fall protection equipment for a maximum of two people.

* DGUV Deutsche Gesetzliche Unfallversicherung:
German occupational safety insurance.



General information

- The identification cap is installed together with the fixing anchor and must remain visible after installation.
- A suitable approved eye-bolt must be used. The required certification as a personal fall attachment point must be supplied by the manufacturer of the eye-bolt.
- Before each use of the PSA personal fall protection, check that the eye-bolt is completely inserted into the cast-in fixing anchor; the thread must not be visible.
- The eye-bolt can be removed when not being used as a PSA personal fall protection point.
- We recommend sealing the fixing anchor with the appropriate sealing cap when not in use.

Installation components and order numbers

Fixing anchor T-FIXX®

T-FIXX® - M16 × 110 A4 - FP

Colour identification cap: light grey

Order no. 0020.270-00508

**Alternative methods for fixing the T-FIXX to formwork (see also following page)****Fixing plate**

Type 2275 (h=2 mm)

 $d_{nom} = M16$

Order no. 0021.090-00003

**Fixing pin**

Type 2250

 $d_{nom} = M16$, \varnothing drill hole = 17 mm

Order no. 0021.020-00005

**Thread adapter**

Type 2600

 $d_{nom} = M16$, d_b for bolt = M8

Order no. 0021.060-00002

**Sealing cap**

Article name: 2244 - M16

Material: plastic

Colour: black

Order no. 0021.030-00005

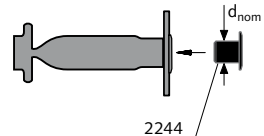
**Sealing cap**

Article name: 6315 - 16

Material: plastic

Colour: light grey

Order no. 0741.130-00003

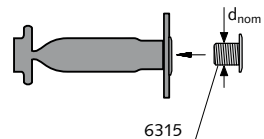
**Suitable eye-bolt anchor, separately available**

RUD PSA-INOX-STAR-Eyebolt M16 (7996757)

Anchorage point, rotating 360°

proofed and certified by PSA Test- and Certification department of DGVU Test, PSA-INOX-STAR made of stainless steel, colour yellow

Order no. 0742.260-00001

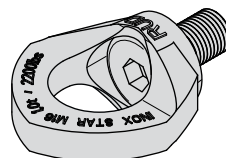
**Notes**

- Make sure the anchors are clean, remove foreign substances, lubricants etc., to ensure a good bond with the concrete.
- Pour the concrete carefully; avoid direct contact between the vibrator and the anchor.
- We recommended additional wire-tying of the anchors to the reinforcement.
- Fixing anchors for PSA applications are installed flush to the surface.
- Unscrew fixing elements directly after removing the formwork.

Installation of the fixing anchor as an attachment point for a PSA

1.) Fixing to the formwork

! see notes on page 3

Case A
fixing with plastic fixing plate

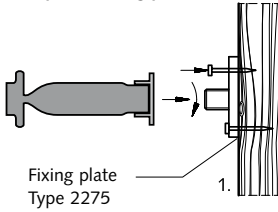

Fixing plate
Type 2275

2.) Preparation

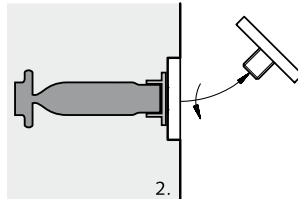

Remove the formwork
Remove the fixing plate

3.) Attach the PSA eye-bolt

Case B
fixing with fixing pin

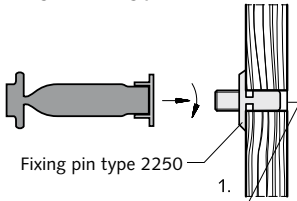

Fixing pin type 2250

Drill hole in the formwork

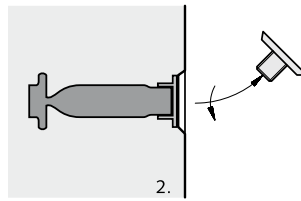

Remove the formwork
Un-screw the fixing pin

Case C
with bolt

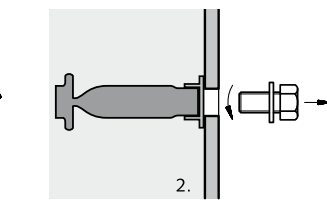
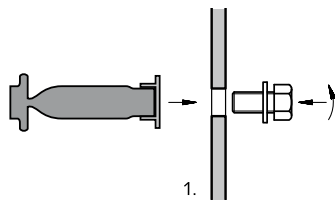

Un-screw the bolt
Remove the formwork

Case D
with thread adapter and hexagonal headed bolt

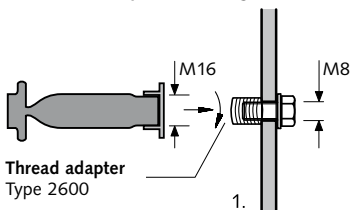

Thread adapter
Type 2600

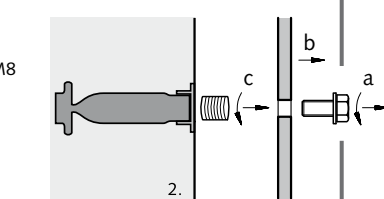

a) Remove bolt
b) Remove formwork
c) Un-screw the thread adapter

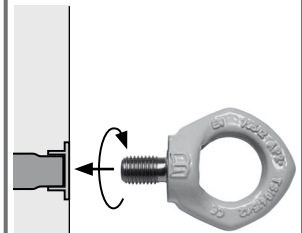

Screw in the
PSA eye-bolt

HALFEN Anschlagpunkt zum Einschrauben einer persönlichen Schutzausrüstung PSA nach DIN EN 795

Der Anschlagpunkt für die persönliche Schutzausrüstung (PSA) besteht aus einem zugelassenen Hülsenanker aus Edelstahl vom Typ DEMU T-FIXX®, einem Datenclip zur Kennzeichnung und einer zugelassenen Ringschraube. Die Eignung des zugelassenen Hülsenankers DEMU T-FIXX® als Anschlagpunkt für eine Einrichtung, zum Schutz gegen Absturz für maximal zwei Personen, wurde durch DGUV-Test in Anlehnung an CEN/TS 16415 geprüft (DGUV = Deutsche Gesetzliche Unfallversicherung).

DEMU T-FIXX® M16, A4

passende Ringschraube zum Beispiel RUD PSA INOX STAR M16 ist separat erhältlich

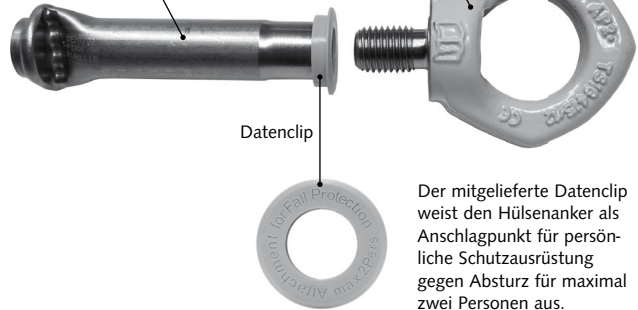

Datenclip

Der mitgelieferte Datenclip weist den Hülsenanker als Anschlagpunkt für persönliche Schutzausrüstung gegen Absturz für maximal zwei Personen aus.



Allgemeine Hinweise

- Der Datenclip wird zusammen mit dem Anker eingebaut und muss auch nach dem Einbau sichtbar sein.
- Es ist eine passende Ringschraube zu verwenden, die vom Hersteller die Zulassung als Personenschutzsicherung aufweist.
- Vor jeder Benutzung der PSA ist optisch zu kontrollieren, dass das Gewinde der Ringschraube nicht mehr sichtbar ist, sondern komplett in den Anschlagpunkt eingedreht ist.
- Nach der Nutzung als PSA kann die Ringschraube wieder herausgedreht werden.
- Es wird empfohlen, bei Nichtgebrauch die Hülsenanker mit einem Verschluss-Stopfen zu verschließen.

Montagekomponenten und Bestellnummern

Hülsenanker T-FIXX®

T-FIXX® - M16 × 110 A4 - FP
Farbe Datenclip: lichtgrau

Bestell-Nr. 0020.270-00508

**Hinweise**

- Für sauberen Verbund zwischen Hülsenanker und Beton ist sicherzustellen, dass der Anker nicht mit Fremdkörpern, Öl usw. verschmutzt ist.
- Beton sorgsam einbringen. Direkten Kontakt zwischen Rüttler und Anker vermeiden.
- Zusätzliches Anrödeln der Anker an die Bewehrung ist zu empfehlen.
- Die Hülsenanker für PSA werden oberflächenbündig eingebaut.
- Haltescheiben unmittelbar nach dem Ausschalen herausdrehen.

Alternative Hilfsmittel zur Befestigung des T-FIXX an der Schalung (s. auch folgende Seite)**Haltescheibe**

Typ 2275 (h = 2 mm)
 $d_{\text{nom}} = \text{M16}$

Bestell-Nr. 0021.090-00003

**Montage-Bruchdübel**

Typ 2250
 $d_{\text{nom}} = \text{M16}$,
Ø Bohrloch = 17 mm

Bestell-Nr. 0021.020-00005

**Gewindeadapter**

Typ 2600
 $d_{\text{nom}} = \text{M16}$,
 d_{B} Schraube = M8

Bestell-Nr. 0021.060-00002

**Verschlussstopfen**

Artikelbezeichnung: 2244 - M16
Material: Kunststoff
Farbe: schwarz

Bestell-Nr: 0021.030-00005

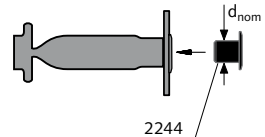
**Verschlussstopfen**

Artikelbezeichnung: 6315 - 16
Material: Kunststoff
Farbe: lichtgrau

Bestell-Nr: 0741.130-00003

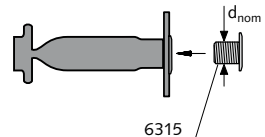
**Passende Ringschraube ist optional erhältlich**

RUD PSA-INOX-STAR-Ringschraube M16 (7996757)
Anschlagpunkt 360° drehbar
Geprüft und zertifiziert durch den Fachbereich PSA der DGUV, PSA-INOX-STAR aus rostfreiem Edelstahl, Farbe gelb

Bestell-Nr: 0742.260-00001

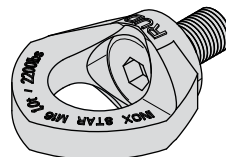

Einbau des Hülsenankers als Anschlagpunkt für PSA

1.) Befestigung an der Schalung

! siehe Hinweise S. 6

Fall A
mit Kunststoff-Haltescheibe

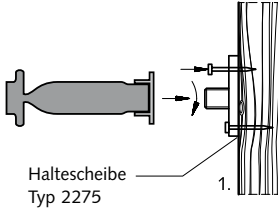

Haltescheibe
Typ 2275

2.) Vorbereitung zur Montage

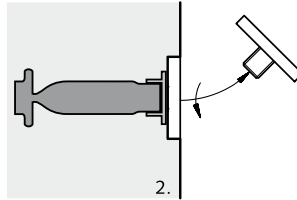

Schalung entfernen,
Haltescheibe herausdrehen

3.) Einschrauben der PSA Ringschraube

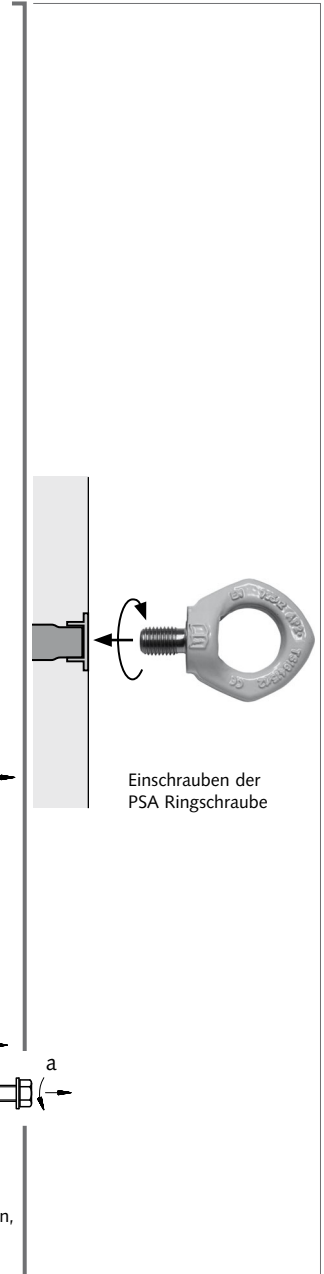

Einschrauben der
PSA Ringschraube

Fall B
mit Montage-Bruchdübel

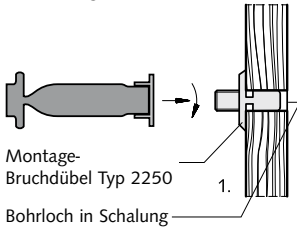

Montage-
Bruchdübel Typ 2250

Bohrloch in Schalung

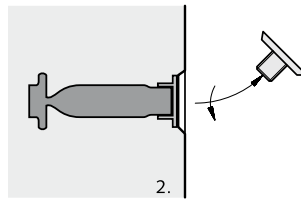

Schalung entfernen,
Gewindeteil herausdrehen

Fall C
mit Sechskantschraube

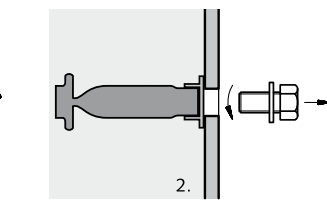
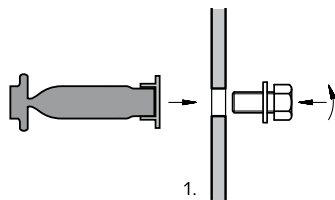

Sechskantschraube herausdrehen,
Schalung entfernen

Fall D
mit Gewindeadapter und Sechskantschraube

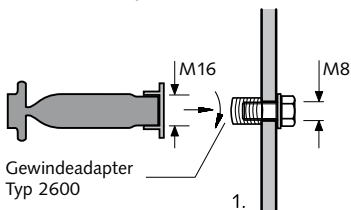

Gewindeadapter
Typ 2600

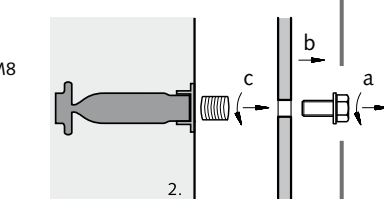

a) Sechskantschraube herausdrehen,
b) Schalung entfernen,
c) Gewindeadapter herausdrehen

CONTACT HALFEN WORLDWIDE

HALFEN is represented by subsidiaries in the following countries, please contact us!

Austria	HALFEN Gesellschaft m.b.H. Leonard-Bernstein-Str. 10 1220 Wien	Phone: +43-1-2596770 E-Mail: office@halfen.at Internet: www.halfen.at	
Belgium / Luxembourg	HALFEN N.V. Borkelstraat 131 2900 Schoten	Phone: +32-3-6580720 E-Mail: info@halfen.be Internet: www.halfen.be	Fax: +32-3-6581533
China	HALFEN Construction Accessories Distribution Co.Ltd. Room 601 Tower D, Vantone Centre No.A6 Chao Yang Men Wai Street Chaoyang District Beijing · P.R. China 100020	Phone: +86-1059073200 E-Mail: info@halfen.cn Internet: www.halfen.cn	Fax: +86-1059073218
Czech Republic	HALFEN s.r.o. Business Center Šafránkova Šafránkova 1238/1 155 00 Praha 5	Phone: +420-311-690060 E-Mail: info@halfen.cz Internet: www.halfen.cz	Fax: +420-235-314308
France	HALFEN S.A.S. 18, rue Goubet 75019 Paris	Phone: +33-1-44523100 E-Mail: halfen@halfen.fr Internet: www.halfen.fr	Fax: +33-1-44523152
Germany	HALFEN Vertriebsgesellschaft mbH Liebigstr. 14 40764 Langenfeld	Phone: +49-2173-9700 E-Mail: info@halfen.de Internet: www.halfen.de	Fax: +49-2173-970225
Italy	HALFEN S.r.l. Soc. Unipersonale Via F.lli Bronzetti N° 28 24124 Bergamo	Phone: +39-035-0760711 E-Mail: tecnico@halfen.it Internet: www.halfen.it	Fax: +39-035-0760799
Netherlands	HALFEN b.v. Oostermaat 3 7623 CS Borne	Phone: +31-74-267 1449 E-Mail: info@halfen.nl Internet: www.halfen.nl	Fax: +31-74-267 2659
Norway	HALFEN AS Postboks 2080 4095 Stavanger	Phone: +47-51823400 E-Mail: post@halfen.no Internet: www.halfen.no	
Poland	HALFEN Sp. z o.o. Ul. Obornicka 287 60-691 Poznan	Phone: +48-61-622 1414 E-Mail: info@halfen.pl Internet: www.halfen.pl	Fax: +48-61-622 1415
Spain	HALFEN IBERICA, S.L. Poligono Industrial Santa Ana c/ Ignacio Zuloaga 20 28522 Rivas-Vaciamadrid	Phone: +34-91 632 18 40 E-Mail: info@halfen.es Internet: www.halfen.es	Fax: +34-91 633 42 57
Sweden	Halfen AB Vädersgatan 5 412 50 Göteborg	Phone: +46-31-985800 E-Mail: info@halfen.se Internet: www.halfen.se	Fax: +46-31-985801
Switzerland	HALFEN Swiss AG Hertistrasse 25 8304 Wallisellen	Phone: +41-44-8497878 E-Mail: info@halfen.ch Internet: www.halfen.ch	Fax: +41-44-8497879
United Kingdom / Ireland	HALFEN Ltd. A1/A2 Portland Close Houghton Regis LU5 5AW	Phone: +44-1582-470300 E-Mail: info@halfen.co.uk Internet: www.halfen.co.uk	Fax: +44-1582-470304
United States of America	HALFEN USA Inc. PO Box 18687 San Antonio TX 78218	Phone: +1 800.423.9140 E-Mail: info@halfenusa.com Internet: www.halfenusa.com	Fax: +1 877.683.4910
For countries not listed HALFEN International	HALFEN International GmbH Liebigstr. 14 40764 Langenfeld / Germany	Phone: +49-2173-970-0 E-Mail: info@halfen.com Internet: www.halfen.com	Fax: +49-2173-970-849

NOTES REGARDING THIS DOCUMENT

Technical and design changes reserved. The information in this publication is based on state-of-the-art technology at the time of publication. We reserve the right to make technical and design changes at any time. HALFEN GmbH shall not accept liability for the accuracy of the information in this publication or for any printing errors.

The HALFEN GmbH subsidiaries in Germany, France, the Netherlands, Austria, Poland, Switzerland and the Czech Republic are Quality Management certified according to **ISO 9001:2015**, Certificate no. 202384-2016-AQ-GER-DakkS.

